

Please read this manual carefully before installation and keep it for future reference.

Installation & Owner's Manual



MRCOOL®

COMFORT MADE SIMPLE

DIY® E Star™ Series

Due to updates and constantly improving performance, the information and instructions within this manual are subject to change without notice. Please visit www.mrcool.com/documentation to ensure you have the latest version of this manual.

Version Date: 03-30-21

!	Safety Precautions	
	Warnings	3
	Cautions	4
1	Parts Overview	
	Parts Diagram	5
	Display Window	6
	Accessories	7
2	Operating Instructions	
	Operating Temperature	9
	Manual Operation	9
	Airflow Directional Control	10
	How the A/C & Heat Pump Work	11
	Special Functions	12
3	Care and Maintenance	
	Before Maintenance	13
	Cleaning the Unit	13
	Cleaning the Air Filter(s)	13
	Preparation for Extended Non-Operation	14
	Pre-Season Inspection	14

DISCLAIMER: You are assuming the risk by handling materials containing refrigerants under pressure, that if not handled properly, can cause bodily injury. If you do not feel comfortable conducting this installation process, we recommend you retain the services of a qualified HVAC professional.
Electrical work must be completed by a qualified electrical technician.

4 Indoor Unit Installation15

1. Selecting an installation location15
2. Attach mounting plate to wall16
3. Drill wall hole for connective piping16
4. Prepare refrigerant piping18
5. Mount indoor unit18

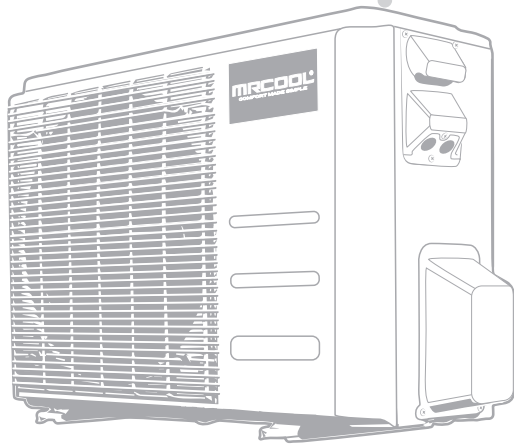

5 Outdoor Unit Installation 19

1. Selecting an installation location19
2. Install drain joint20
3. Anchor outdoor unit21

6 Refrigerant Piping Connections.....23

1. Prepare Exterior Wall Hole 23
2. Unwind Quick Connect® Line Set to necessary length 23
3. Connect Line Set to Indoor Unit 24
4. Connect Line Set to Outdoor Unit 26
5. Opening Refrigerant Valves of Outdoor Unit 28
6. Connect drain pipe 29
7. Wrap Piping Connections 30

7 Electrical Connections32

8 Electrical and Gas Leak Checks.....34

9 Test Run.....35

10 Troubleshooting.....37

Safety Precautions



Read Before Using

Incorrect usage may cause serious damage or injury.

The symbols below are used throughout this manual to indicate instructions that should be followed closely or actions that should be avoided to prevent death, injury, and/or property damage.



WARNING

This symbol indicates ignoring instructions may cause death or serious injury



CAUTION

This symbol indicates ignoring instructions may cause bodily injury, damage to the unit, or other surrounding property.



This symbol indicates that you should NEVER perform the indicated action.



WARNING

DISCLAIMER: You are assuming the risk by handling materials containing refrigerants under pressure, that if not handled properly can cause bodily injury. If you do not feel comfortable conducting this installation process, we recommend you retain the services of a qualified HVAC professional.

Electrical work must be completed by a qualified electrical technician.

- ⊘ **DO NOT** share the electrical circuit with other appliances. Improper or insufficient power supply can cause fire or electrical shock.
 - ⊘ When connecting the refrigerant piping, **DO NOT** allow any other substances or gases enter the unit. The presence of other gasses or substances will lower the unit's capacity, and may cause abnormally high pressure in the operation cycle. This could cause an explosion and/or injury.
 - ⊘ **DO NOT** allow children to play with the air conditioner. Children should be supervised around the unit at all times.
1. Installation must be performed according to installation instructions. Improper installation may cause water leakage, electrical shock, fire, or may void the warranty.
 2. In North America, service or repair must be performed in accordance with the requirement of NEC and CEC (by authorized personnel or authority having jurisdiction only.) Contact an authorized service technician for repair or maintenance of the unit.
 3. Only use the included accessories and specified parts for installation. Using non-standard parts can cause water leakage, electrical shock, or fire and may cause the unit to fail.
 4. Install the unit in a firm, stable location that can support the weight of the unit. If the installation location cannot support the weight of the unit, it could fall and cause serious injury and/or damage.
 5. For all electrical work, follow all appropriate wiring standards, regulations, and the Installation Manual.
 6. You must use an independent circuit to supply power. Do not connect other appliances to the same circuit. Insufficient electrical capacity or defects in electrical work can cause electrical shock or fire.

WARNING

7. For all electrical work, fuse the specified cables. Connect cables tightly, and clamp them securely to prevent external forces from damaging the terminal. Improper electrical connections may overheat, causing fire and/or electrical shock.
8. All wiring must be properly arranged to ensure that the control board cover can close properly. If the control board cover is not closed properly, it can lead to corrosion, which can cause the connection points on the terminal to overheat, which can result in fire and/or electrical shock.
9. If connecting power to fixed wiring, the following must be incorporated within it, in accordance with the wiring rules; an all-pole disconnection device (which has at least 3 mm of clearances in all poles), and have a leakage current that may exceed 10mA, the residual current device (RCD) having a rated residual operating current not exceeding 30mA, and disconnection all must be present.
10. In certain functional environments, such as kitchens, server rooms, etc., the use of specially designed air-conditioning units is highly recommended. If the supply cord is damaged, it must be replaced by the manufacturer, its service agent or similarly qualified persons in order to avoid a hazard.
11. This appliance is not intended for use by individuals (including children) with reduced physical, sensory, or mental capabilities. It is also not intended for use by individuals with a lack of experience or knowledge, unless they have been given supervision or instruction concerning use of the appliance by a person responsible for their safety. Children should be supervised at all time to ensure that they do not play with the appliance.

CAUTION

- ⊘ For units that have an auxiliary electric heater, ***DO NOT*** install the unit within 3 feet (1 meter) of combustible materials.
 - ⊘ ***DO NOT*** install the unit in a location that may be exposed to combustible gases. If combustible gas accumulates around the unit, it may cause fire.
 - ⊘ ***DO NOT*** operate your air conditioner in a room where it could be exposed to water, such as a bathroom or laundry room. Exposure to excessive amounts of water may cause electrical components to short circuit.
 - ⊘ ***DO NOT*** operate the air conditioner with wet hands. This may cause electrical shock.
 - ⊘ ***DO NOT*** climb onto or place objects on top of the outdoor unit.
1. The product must be properly grounded during installation, or electrical shock may occur.
 2. Install drainage piping according to the instructions in this manual. Improper drainage may cause water damage to your home and property.

Note about Fluorinated Gases:

1. This air-conditioning unit contains fluorinated gases.
2. For specific information on the type of gas and the amount, please refer to the relevant label on the unit itself.
3. Service, maintenance, and repair of this unit must be performed by a certified technician.
4. Product uninstallation and recycling must be performed by a certified technician.
5. If the system has a leak-detection system installed, it should be checked for leaks at least every 12 months.
6. Keep a record of all leak checks for the lifetime of the unit.

NOTE: The installation must be performed in accordance with the requirement of local and national standards. Both power cable and signal cable should be protected by the conduit.

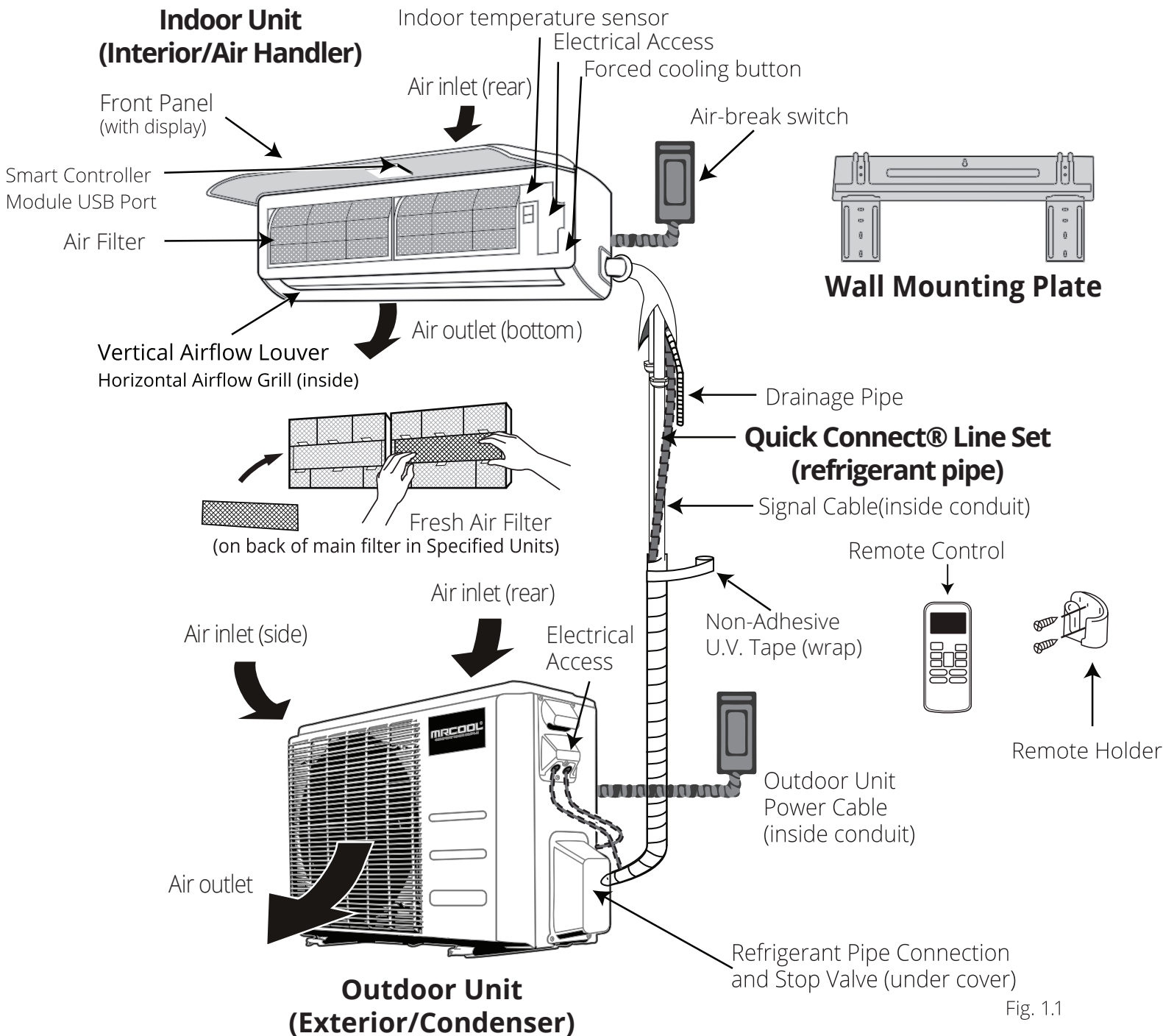

Fig. 1.1

NOTE ON ILLUSTRATIONS

Illustrations in this manual are for explanatory purposes. The actual shape of your unit may vary.

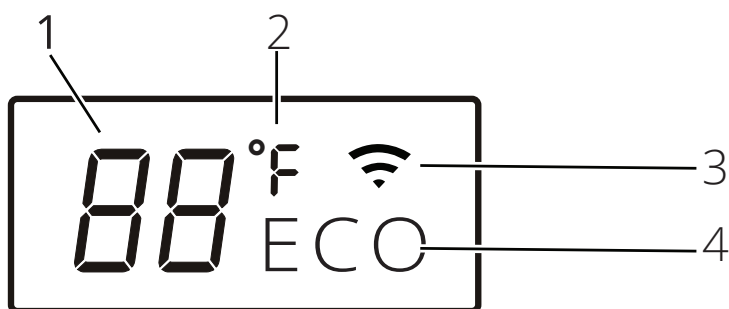

Fig. 1.2

Display (on front panel of indoor unit) see fig. 1.2

1. Digital Display:

Displays the Temperature Setting when the air conditioner is operational.

Displays the Room Temperature when in FAN mode.

Displays the self-diagnostic codes.

Displays "ON" for three seconds when the Timer is ON and/or Fresh, Swing, Turbo, or Silence feature is activated.

Displays "OF" for three seconds when the Timer is switched OFF.

Displays "OF" for three seconds when the Fresh, Swing, Turbo, or Silence feature is canceled.

Displays "dF" when Defrosting operation is active.

Displays "cF" when Anti-Cold Air feature is active in HEAT mode (when air temp is low).

Displays "SC" during Self Clean operation (if feature is available).

Displays "FP" when Freeze Protection is active, operating under 46.4 °F (8 °C) (if feature is available).

2. Units of Measurement:

Displays "°C" for Celsius or, "°F" for Fahrenheit. Default units are "°F" (Fahrenheit) and can be switched by simultaneously pressing and holding both the up and down buttons on the remote control.

According to the operation mode (heat/cool, etc.), the Units of Measurement will display in different colors;

- Under Cool or Dry mode, it always displays as cool colors (Blue).
- Under Heat mode, it always displays as a warm color (Red).

3. Wireless Mode:

Displays when the wireless control feature is activated.









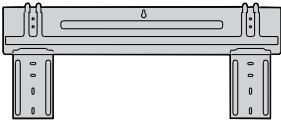

NOTE: A guide for using the infrared remote can be found in the "Remote Control User Manual" which is included in this literature package.

4. Energy Saving Mode:

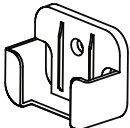
Displays when Energy Saving Feature is active. Not available on units not equipped with this feature.



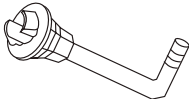





Accessories

The air conditioning system includes the following accessories. Use all of the installation parts and accessories to install the air conditioner. Improper installation may result in water leakage, electrical shock, fire, or equipment failure.

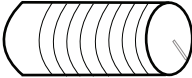
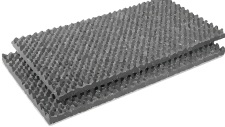
PART	LOOKS LIKE...	QUANTITY	
Mounting plate		1	
Anchor		5	
Mounting plate fixing screw		5	
Remote control		1	
Fixing screw for remote controller holder ST2.9 x 10		2	Optional Parts
Remote control holder		1	
Dry battery AAA.LR03		2	
Air freshening filter		1	
Seal		1	
Allen wrench		1	
Drain joint		1 (Only for use when elevated)	
Neoprene		1 (Sealant for Wall Sleeve)	

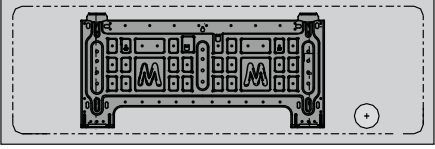
Note: Illustrations are for explanatory purposes only - The actual shape and size may vary.

Accessories

PART	LOOKS LIKE...	QUANTITY
Installation & Owner's Manual		1
Remote Control User Manual		1
Smart Controller Kit		1 (w/ Manual in Controller Box)
Plastic Wall Sleeve		1
Sound deadening pads		2
Drain Pipe		1 16 ft (5 m)
Cardboard Mounting Plate Template		1
Quick Connect® Line Set (refrigerant pipe)		1
Insulation material		2 (Apply to the quick connectors of the pipe)
Non-Adhesive U.V. Tape		1

	Cooling Operation	Heating Operation	Drying Operation
Room Temperature	63°F~90°F (17°C~32°C)	32°F~86°F (0°C~30°C)	50°F~90°F (10°C~32°C)
Outdoor Temperature	32°F~122°F (0°C~50°C)	5°F~75°F (-15°C~24°C)	32°F~122°F (0°C~50°C)
	5°F~122°F / -15°C~50°C (For the models with low ambient cooling system)		

NOTE:

1. Optimum performance will be achieved within these operating temperatures. If air conditioner is used outside of the above conditions, certain safety protection features might come into operation and cause the unit to function abnormally.
2. If the air conditioner runs for a long time in cooling mode and the humidity is high (over 80%), condensed water may drip out of the unit. In this case, set the vertical air flow louver to its maximum angle (vertical toward the floor), and set it to HIGH fan mode.

Manual Operation

Units are equipped with a button to run emergency operation mode. This button is used for manual operation in case the remote control fails, or maintenance is necessary. This can be accessed by opening the front panel.

NOTE: The unit must be turned off before operating the manual control button. If the unit is operational, continue pressing the manual control button until the unit is off.

1. Open and lift the front panel up to an angle until it remains fixed with a clicking sound.
2. One press of the manual control switch will lead to the forced AUTO operation. If the switch is pressed twice within five seconds, the unit will operate under forced COOL operation.
3. Close the panel firmly to its original position.

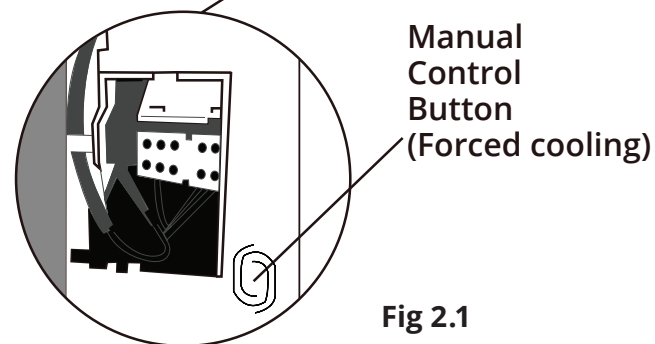
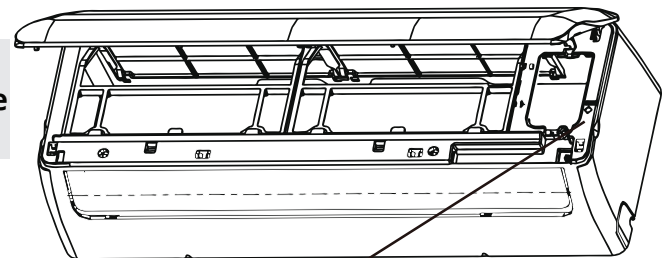

Fig 2.1

CAUTION

- This button is used for testing purposes only. Please do not use it unless necessary.
- To restore the remote control operation, use the remote control directly.

Airflow Directional Control

- Adjustment of the vertical and horizontal louvers will change airflow direction of the indoor unit to prevent discomfort and/or uneven room temperatures.
- Adjust the vertical louver using the remote.
- Adjust the horizontal louver manually.

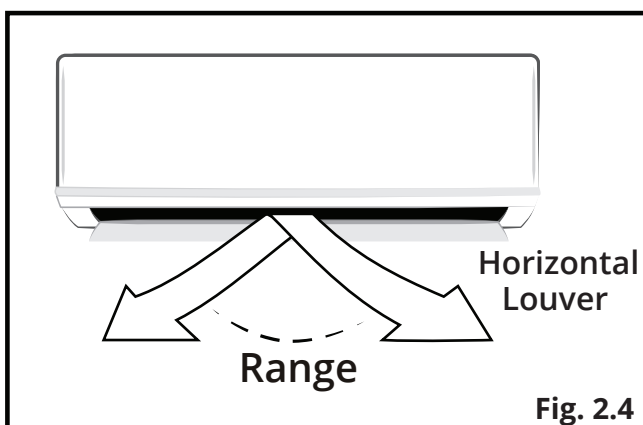
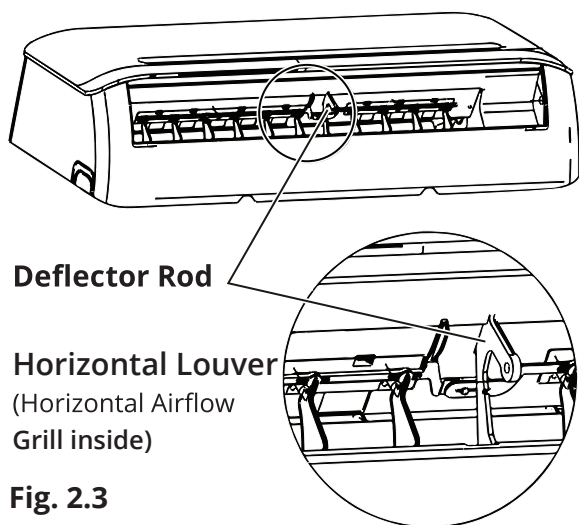
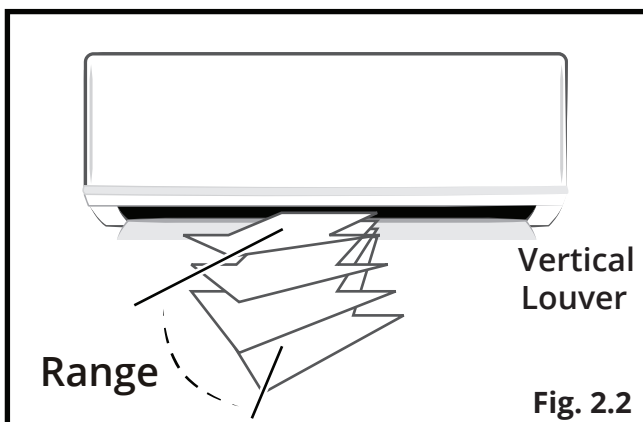

Adjust Vertical Airflow (Up/Down) using Vertical Louver (Fig 2.2):

This function is performed by using the remote control, while the unit is operating. The Vertical louver can move in small increments for each press, or continuously swing up and down automatically. Please refer to the "**Remote Control User Manual**" for further details.

Adjust Horizontal Airflow (Left/Right) using Horizontal Louver (Fig 2.3 & Fig 2.4)

Move the deflector rod, located on the underside of the unit, by pushing the tab to manually adjust the airflow from side to side as desired.

! CAUTION

- ⚠ **DO NOT** put your fingers into the panel of the blower and suction side. The high speed fan inside may cause injury.
- ⚠ **DO NOT** operate the unit for long periods of time in cooling or dehumidifying mode with the airflow direction set downward. This could cause condensation to form on the surface of the vertical louver and allow moisture to drop onto furnishings or the floor.
- ⚠ **DO NOT** move the vertical louver manually, as this cause it to become out of sync. If this occurs, follow these steps:
 1. Turn off power to the unit
 2. Remove wireless module from back of front cover
 3. Turn off power to the circuit at the breaker
 4. Wait a few seconds and turn the power back on at the breaker
 5. Reinstall wireless module into front cover
 6. Turn the power to the unit back on

NOTE: After a quick restart, the vertical louver may remain static for approximately 10 seconds.

NOTE: Open angle of the vertical louver should not be set too small, as it will restrict airflow and reduce **COOLING** and **HEATING** performance of the unit.

Operating Instructions

How the air conditioner works

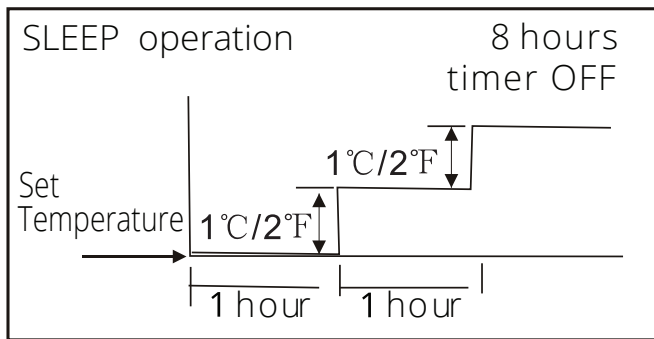

SLEEP Operation While Cooling

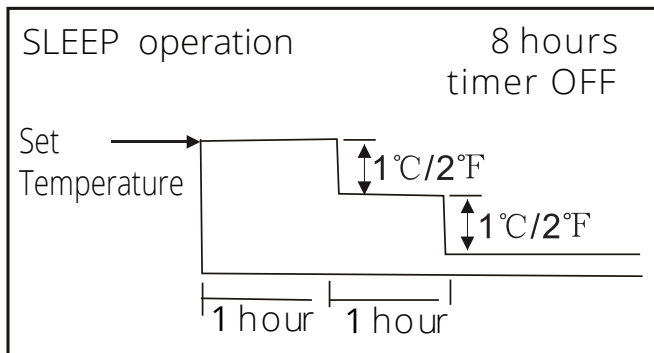

SLEEP Operation While Heating

Basic Operation Modes:

AUTO / COOL / DRY / HEAT (Model dependent).

Auto Operation:

When you set the air conditioner in **AUTO** mode, it will automatically select cooling, heating or fan-only operation depending on set temperature and room temperature.

The unit will control the room temperature automatically, according to the temperature point you set.

SLEEP Operation:

When selected, the temperature will increase while cooling or decrease while heating by 1°C/2°F per hour for the first 2 hours. Thereafter it keeps this new temperature for 6 hours before **SLEEP** mode switches off.

DRYING Operation:

The temperature is regulated while dehumidifying by intermittently switching the cooling or fan-only operation on and off. The fan speed is set to **LOW**.

HEATING Operation:

This unit is a heat pump by design. By reversing the air conditioning process, it absorbs heat from outdoors and transfers it to the indoor unit. As a result, the operating performance and efficiency is reduced as the outdoor air temperature drops. If you feel that the heating performance is insufficient, it is recommended that you supplement heating with other appliances.

Optimal Operation

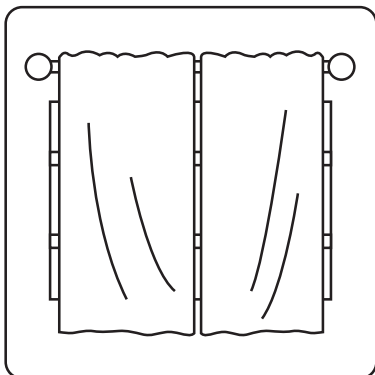

Closing the curtains while heating also helps keep the heat in

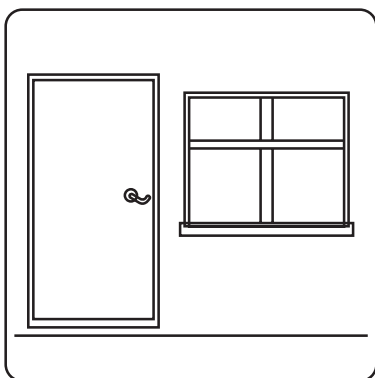

Doors and windows should be kept closed

To achieve optimal performance, please note the following:

- Adjust the airflow direction correctly, so that it is not towards people or at an extreme angle.
- Adjust the temperature to achieve moderate comfort levels. An excessively low or high temperature setting wastes energy.
- Keep windows and doors closed, as this improves performance.
- Limit energy usage (run time) by using the **TIMER** function.
- Do not put any objects near the air inlets/outlets. Doing so would impair performance and possibly shut down the unit.
- Inspect the air filters periodically, and clean them as needed.

Special Functions

Refrigerant Leakage Detection (optional):

When refrigerant leakage is detected, the indoor unit will display “EC” or “ELOC” code or flash LEDs, depending on the model.

Louver Angle Memory Function (optional):

Within the scope of the safe operation angle, the horizontal louver angle is memorized and returns to the position last selected by the user. If it exceeds the safe operation angle, it will default within the safe operation range. However, it will not return to safe operation angle when Turbo mode is set or the unit is in manual control or after a power interruption. Subsequently, it is strongly recommended that the horizontal louver angle not be set too small, to avoid possible condensation leakage.

Anti-Mildew Function (optional):

When the unit is turned off, in COOL, DRY, or AUTO (cool) modes, it will continue to run for about 10 minutes with low fan airflow. This is to aid in drying any condensation that has formed inside the unit to prevent mildew growth. Do not restart the air conditioner until the unit is completely off.

Optimal Operation:

In the event of a power interruption such as a blackout, the air conditioner will stop. It will then restart automatically and resume the previous operation when the power supply returns.

Wireless Smart Control Function:

Connect the wireless control module via the USB port in the back of the front cover of the indoor unit for the unit to be controlled by remote control and/or smartphone app.

Clean Air Filter Reminder (optional):

After 240 hours of operation, the indoor display window will display and flash “CL” as a reminder to **CLEAN** the air filter for more efficient operation. After 15 seconds, the system will revert back to the previous display again. When the “CL” indicator appears and flashes, please press the **LED** button on the remote control 4 times or press the manual control button 3 times to reset the hours. If you don't reset the reminder, the “CL” indicator will flash again when you restart the unit.

Replace Air Filter Reminder (optional):

After 2880 hours of operation, the indoor display window will display and flash “nF” as a reminder to **REPLACE** the air filter for more efficient operation. After 15 seconds, the system will revert back to the previous display again. When the “CL” indicator appears and flashes, please press the **LED** button on the remote control 4 times or press the manual control button 3 times to reset the hours. If you don't reset the reminder, the “nF” indicator will flash again when you restart the unit.

Mute Function (optional):

Press the **LED** button on the remote to turn off the **LED** display and silence the buzzer of the indoor unit, creating a quiet comfortable environment.

! CAUTION

Power supply must be disconnected before attempting any kind of cleaning or service. Before performing maintenance, turn the power off to the unit and then disconnect the power to the circuit at the breaker. Failure to do this could cause electrical shock.

- ⊘ **DO NOT** use benzene, thinner, polishing powder, or similar solvents for cleaning. These may cause the plastic to crack and/or deform.
- ⊘ **DO NOT** clean the unit with excessive amounts of water.
- ⊘ **DO NOT** touch the metal parts of the unit when removing the filter. Injuries can occur when handling the sharp metal edges.
- ⊘ **DO NOT** use water to clean inside the air conditioner. Exposure to water can destroy the insulation, leading to possible electric shock.

- ⊘ **DO NOT** use a chemically treated cloth or duster to clean the unit.
- ⊘ **DO NOT** touch air freshening (Plasma) filter for at least 10 minutes after turning off the unit.
- ⊘ **DO NOT** clean the unit with combustible cleaning agents. These could cause fire or deformation.
- ⊘ **DO NOT** wash air filter with water hotter than 104°F (40°C).
- ⊘ **DO NOT** expose the filter to direct sunlight, it may cause it to shrink. Allow it to dry in the shade.

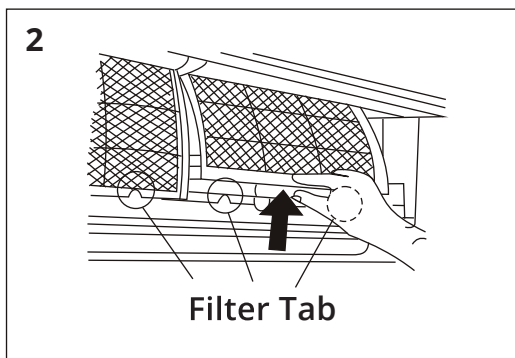
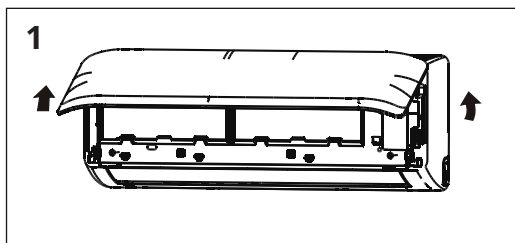

Cleaning the Unit:

Wipe the unit with a soft dry cloth. If the unit is very dirty, wipe it with a cloth soaked in warm water. **DO NOT use bleach or abrasives.**

Cleaning the Air Filter and Air Freshener:

NOTE: A clogged air filter can greatly reduce heating and cooling efficiency of this unit. It is recommended to clean the unit every 2 weeks.

1. Open the front by carefully lifting both ends at the same time. As you continue lifting, at a certain angle there will be an audible click and the lid will become self-supporting. Some models are equipped with suspension bars that are required to prop the lid open.
2. Use the filter tabs to lift filter slightly upward and then pull it towards you.

3. Then, extract the filter by gently drawing it downward. Replace as necessary.
4. Unclip the small air freshening filter from the larger air filter. Replace as necessary. Otherwise, clean it with a vacuum and clip it back into place after cleaning the larger air filter as outlined in step 5.
5. Clean the large air filter with warm, soapy water. Be sure to use a mild detergent. Rinse with fresh water. Shake off excess water and dry in a cool area.
6. Re-clip air freshening filter into large air filter.
7. Re-fit air filter back into the unit by reversing steps 2 and 3 - gently pushing top up into the unit and then lowering the bottom into place.
8. Close the front panel. Make sure that buckles fully fit and the panel is completely closed.

Preparation for Extended non-Operation:

If you plan to not run the unit for a long period of time (e.g. from the end of summer to the beginning of the following summer), perform the following:

1. Clean the indoor unit and filters as previously outlined.
2. Operate the unit in FAN only mode for at least 8 hours to dry out the inside of the unit.
3. Turn off the unit. Then, turn off the power to the circuit at the breaker. The unit should be the only appliance on this circuit.
4. Remove the batteries from the remote control.
5. The outdoor unit also requires periodic maintenance. However, it is highly recommended you contact a qualified service professional to perform this. Please do not attempt to do this on your own.

Pre-Season Inspection:

After prolonged non-operation perform the following:

1. Check for Damaged or Disconnected Wires.
2. Clean the Indoor Unit and Filters
3. Check for Water and Oil Leaks
4. Check for Blockages in Airflow Inlet and Outlet
5. Replace Batteries in Remote Control

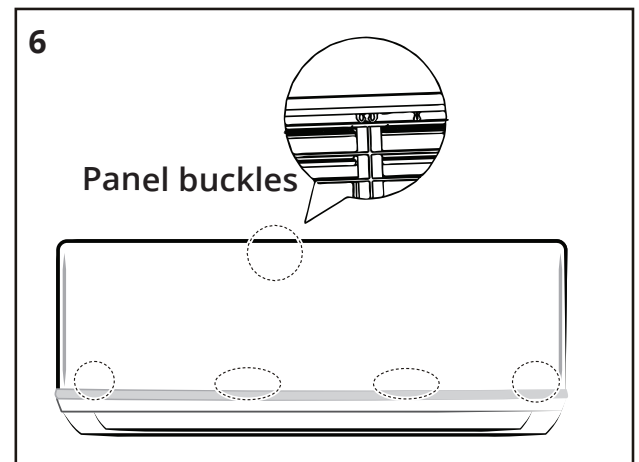
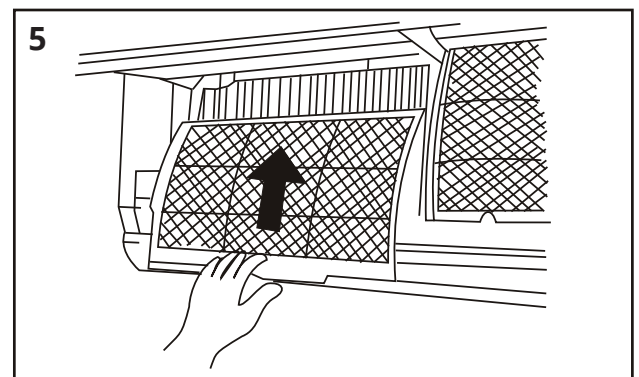
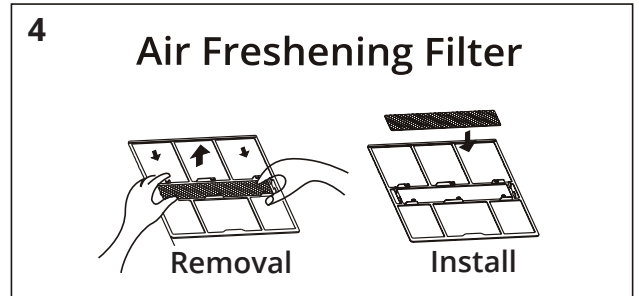
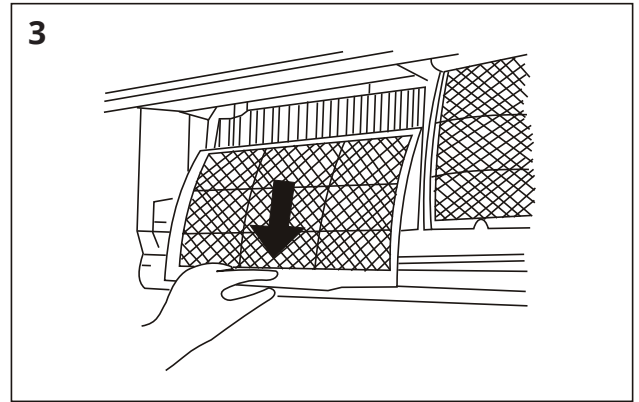

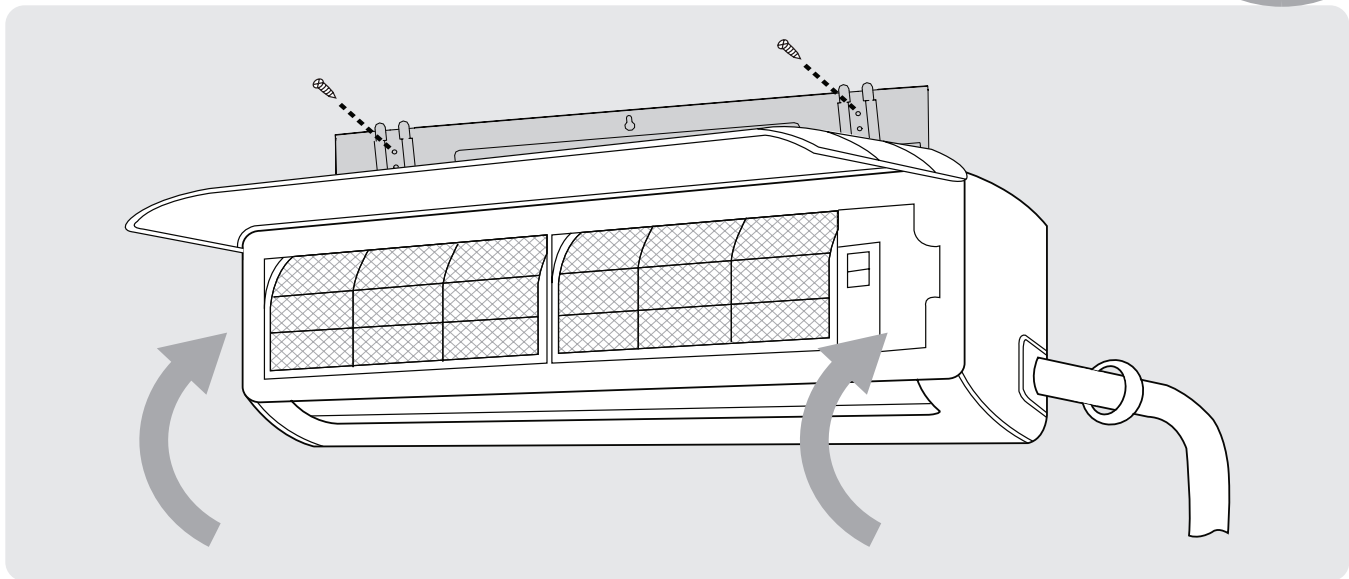

Installation Instructions - Indoor Unit

PRIOR TO INSTALLATION:

Before installing the indoor unit, refer to the label on the product box to make sure that the model numbers of the indoor unit and the outdoor unit match.

Step 1: Selecting an installation location

Before installing the indoor unit, you must choose an appropriate location. The following standards will help you choose an appropriate location for the unit.

Proper installation locations meet the following standards:

- ✓ Good air circulation
- ✓ Convenient drainage
- ✓ Noise from the unit will not disturb other people
- ✓ Firm and solid—the location will not vibrate
- ✓ Strong enough to support the weight of the unit
- ✓ A location at least one meter from all other electrical devices (e.g., TV, radio, computer)

DO NOT install unit in the following locations:

- ⊘ Near any source of heat, steam, or combustible gas
- ⊘ Near flammable items such as curtains or clothing
- ⊘ Near any obstacle that might block air circulation
- ⊘ Near a doorway or where outside air may blow directly on indoor unit
- ⊘ In a location subject to direct sunlight

NOTE ABOUT WALL HOLE:

If there is no fixed refrigerant piping: While choosing a location, be sure that you leave ample room for a wall hole (see the Drill Wall Hole for Connective Piping step on the following pages) for the signal cable and refrigerant piping, which connect the indoor and outdoor units. The default position for all piping is the right-hand side of the indoor unit (while facing the front of the unit). After the piping and signal wire are installed, use the provided neoprene (spray foam can be used instead, if you prefer) to pack the space left in hole, in order to seal it and make it airtight.

Refer to Fig. 4.2 below to ensure proper distance from walls, ceiling, and floor when mounting unit:

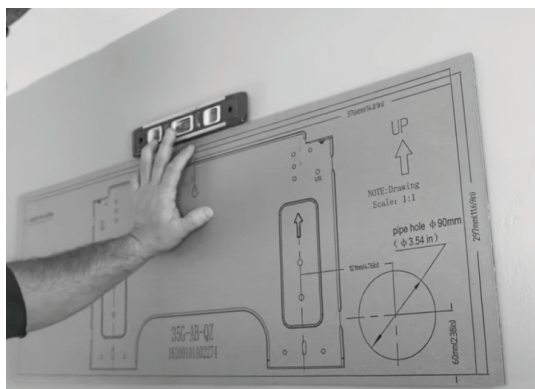

Fig. 4.1

Step 2: Attach mounting plate to wall

The mounting plate is the device on which you will mount the indoor unit.

1. Remove the screw that attaches the mounting plate to the back of the indoor unit.
2. Place the mounting plate against the wall in a location that meets the guidelines in the **Selecting an Installation Location** step. Refer to the **Mounting Plate Dimensions** section for detailed information on mounting plate sizes.

NOTE

A cardboard template of the mounting plate is included to be used as a more manageable way of determining where to mount the mounting plate and drill the wall hole. It can be placed against the wall in place of the actual mounting plate for the previous step (See Fig 4.1).

3. Drill holes for mounting screws in places that:
 - have studs and can support the weight of the unit
 - correspond to screw holes in the mounting plate
4. Secure the mounting plate to the wall with the screws provided.
5. Make sure that mounting plate is flat against the wall.

NOTE FOR CONCRETE OR BRICK WALLS:

If the wall is made of brick, concrete, or a similar material, drill 0.2 in. diameter (5 mm diameter) holes in the wall and insert the sleeve anchors provided. Secure the mounting plate to the wall by tightening the screws directly into the anchors.

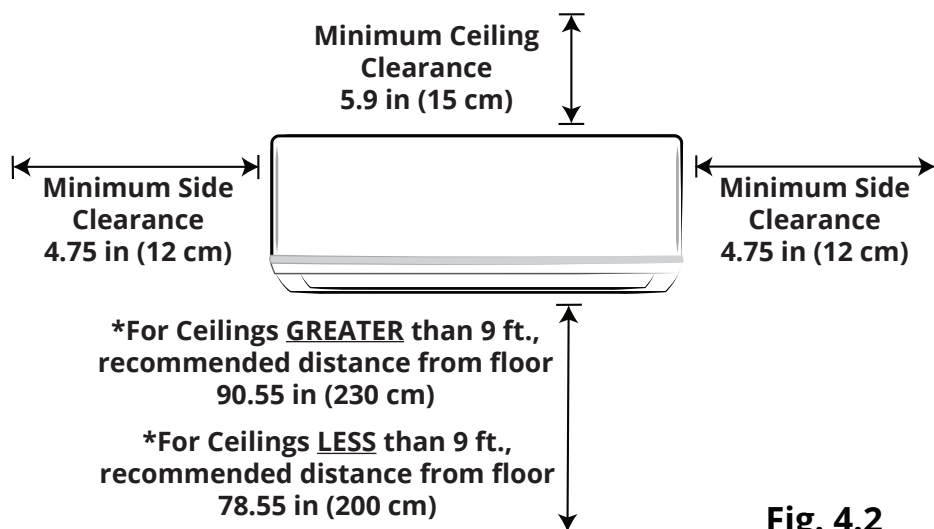

Fig. 4.2

Step 3: Drill wall hole for connective piping

You must drill a hole in the wall for the refrigerant piping, drainage pipe, and signal cable to pass through in order to connect the indoor and outdoor units.

1. Determine the location of the wall hole based on the position of the mounting plate. Refer to the **Mounting Plate Dimensions (See Fig 4.5)** to assist you in determining the optimal position for the hole, based on the type of mounting plate provided with your unit.
2. Using a core drill, with a 3.54 in (90 mm) diameter, drill a hole in the wall at a slight downward angle, so that the indoor end of the hole is higher than the outdoor end of the hole, by approximately 0.2 in to 0.275 in (5 mm to 7 mm). This will ensure proper water drainage from the indoor unit (**See Fig. 4.3**).
3. Insert the protective wall sleeve through the hole of the inside wall, noting the amount it protrudes from the exterior wall. Then, trim the excess, with a utility knife or a saw, to make it flush with the exterior wall. This will protect the edges of the hole and help seal it when you finish the installation process (**See Fig 4.4**).

! CAUTION

When drilling the wall hole, be sure to avoid wires, plumbing, nails, screws, and other sensitive components.

Indoor Unit Installation

MOUNTING PLATE DIMENSIONS

Different models have different mounting plates. In order to ensure that you have ample room to mount the indoor unit, the diagrams to the right show different types of mounting plates along with the following dimensions:

- Height & Width of mounting plate
- Height & Width of indoor unit relative to plate
- Recommended position of wall hole
- Relative distances between screw/mounting holes
- Do not attempt a left rear wall hole.

Correct orientation of Mounting Plate

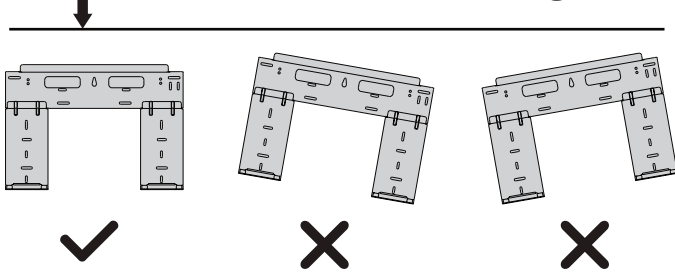

NOTE: Use a level in order to ensure your mounting plate is mounted to the wall with the correct orientation shown above.

Correct Angle to Drill Wall Hole

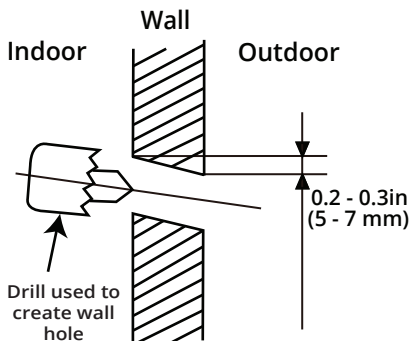

Fig. 4.3

Wall Hole Sleeve Installation



Fig. 4.4

NOTE REGARDING WALL STUDS

1. Wall Mounting Bracket should be installed on studs.
2. Standard US Studs are 16" on-center.
3. 16" on-center correlates with the holds marked "US" on the metal bracket.

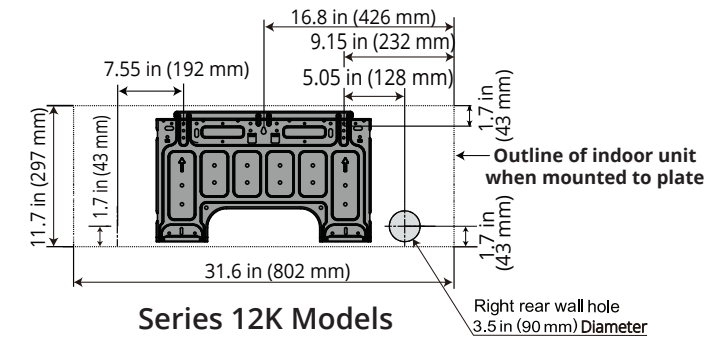

Series 12K Models

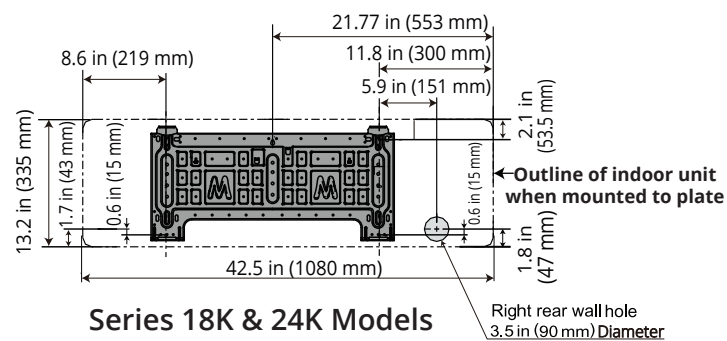

Series 18K & 24K Models

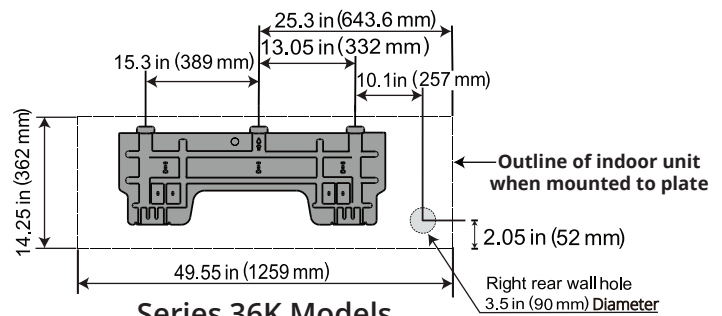

Series 36K Models

Fig. 4.5

UNIT IS ADJUSTABLE

Keep in mind that the hooks on the mounting plate are smaller than the holes on the back of the unit. If you find that there is not enough room to connect embedded pipes to the indoor unit, it can be adjusted left or right by 1.25-1.95 in (30-50 mm), depending on the model.



Adjustment range of indoor unit to the left or right

Step 4: Prepare indoor unit refrigerant piping

The piping of the indoor unit is attached to the back of the unit towards the bottom. It will be covered with insulation, and there will also be a drain pipe with these. This piping will need to be bent and prepared before it can be fed through the wall hole.

NOTE: Refrigerant piping should exit the indoor unit from the right-hand side (Refer to Fig 4.6)

1. Based on the position of the wall hole, relative to the mounting plate, determine the necessary angle the piping will need to be bent to pass through the wall hole when the unit is mounted to the bracket.
2. Grip the refrigerant piping at the base of the bend. Then, slowly, and with even pressure, bend the piping away from the back of the unit roughly 90 degrees. The piping should be sticking straight out from behind the unit once completed (Refer to Fig 4.6).

! CAUTION

Be extremely careful not to dent or damage the piping while bending it away from the unit, as this could negatively affect the performance.

Fig. 4.6

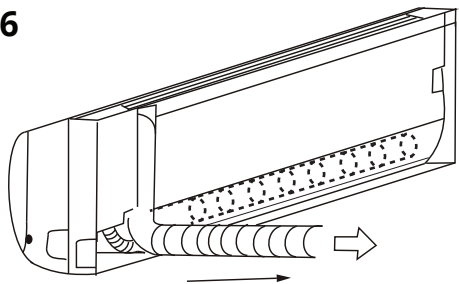

3. Now, you will need to lightly tape the refrigerant piping and drain pipe together in a bundle, using electrical tape, making sure that the drain pipe is at the bottom. **DO NOT** tape the ends of the piping (connectors). Refer to Fig 4.7 and the image below for the correct orientation of the piping when taping.

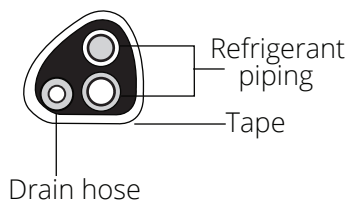

Fig. 4.7

DRAIN HOSE MUST BE ON BOTTOM

The drain hose must be placed at the bottom of the bundle. If it is not, it could cause the drain pan to overflow, which could lead to fire or water damage.

Step 5: Mount the Indoor Unit

In the following steps the indoor unit will now be mounted to the wall bracket and the piping and wires will be fed through the wall hole.

1. Double-check that the ends of the refrigerant pipes are sealed (screw on caps are still in place) to prevent any dirt or foreign material from entering the pipes.
2. Feed the signal wire (should be protected by conduit) through the wall hole.
3. Carefully lift the indoor air handler, and slowly feed the taped bundle of refrigerant pipes and drain hose through the wall hole, as you position it to mount to the wall bracket.

NOTE: Positioning the air handler on to the wall bracket, while feeding the piping through the wall hole, might be difficult for a single person to manage. If so, it may be necessary to seek the assistance of another person for this step.

4. Slightly lean the top of the air handler toward the wall and hook the top of the indoor unit on the upper hook of the wall mounting plate.
5. Check that the unit is hooked firmly on the mounting plate by applying slight pressure to the left and right-hand sides of the unit. The unit should not jiggle or shift.
6. Using even pressure, push down on the bottom half of the unit. Continue pushing down until the unit snaps onto the hooks along the bottom of the mounting plate.
7. Again, check that the unit is firmly mounted to the wall bracket by applying slight pressure to the left and right-hand sides of the unit.



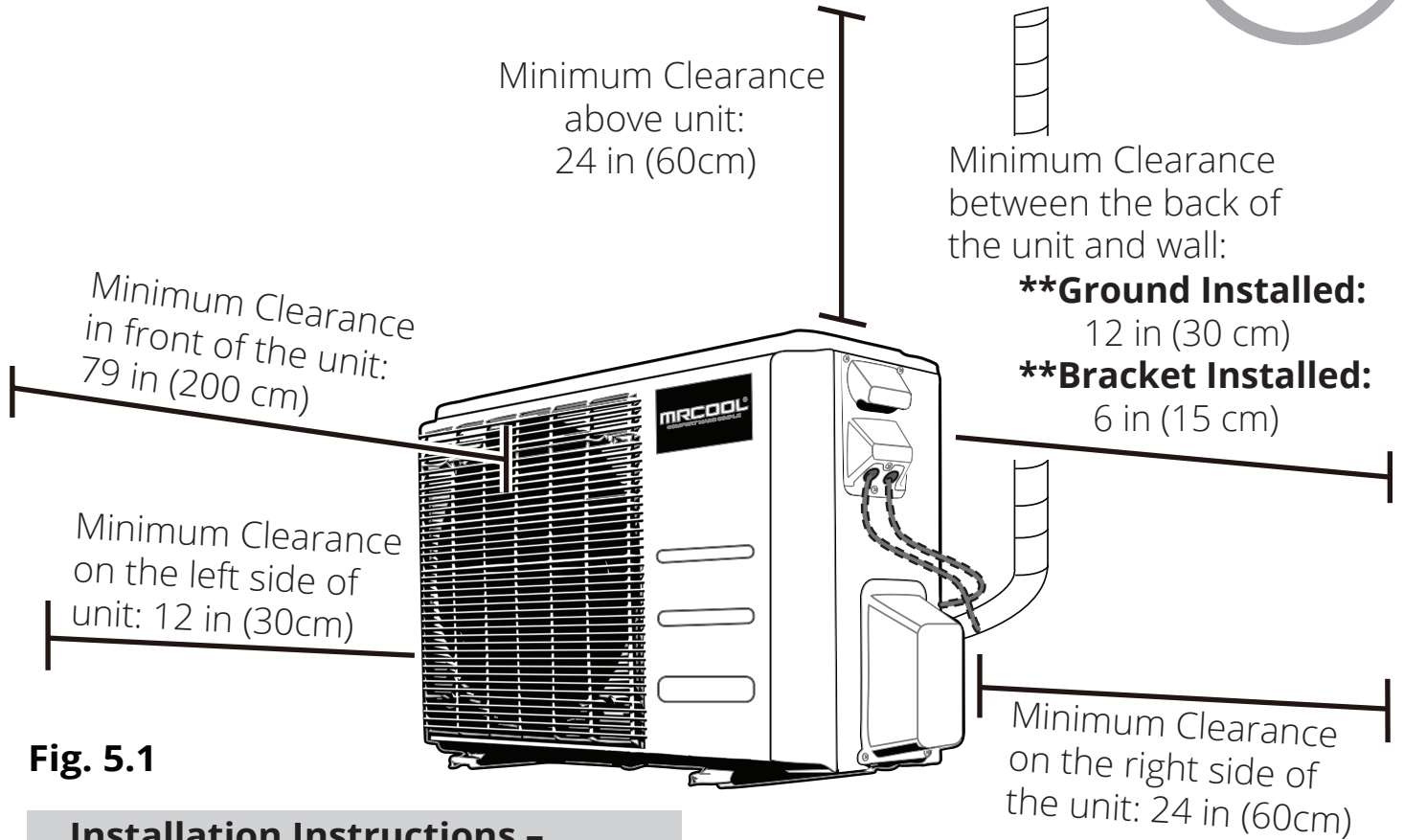

Fig. 5.1

Installation Instructions - Outdoor Unit

Step 1: Selecting an installation location

Before installing the outdoor unit, you must choose an appropriate location. Use the following guidelines to help you select an appropriate location.

Proper installation locations meet the following guidelines:

- Meets all spatial requirements shown in Installation Space Requirements (Fig. 5.1)
- Good air circulation and ventilation
- Firm and solid location that can support the unit and will not cause vibration
- Noise from the unit will not disturb others
- Protected from prolonged periods of exposure to direct sunlight or rain

DO NOT install unit in the following locations:

- Near an obstacle that will block air inlets and outlets
- Near a public street, crowded areas, or where noise from the unit will disturb others
- Near animals or plants that will be harmed by hot air discharge
- Near any source of combustible gas
- In a location that is exposed to large amounts of dust
- In a location exposed to a excessive amounts of salty air
- In a location that exposes the unit to large amounts of forced water

SPECIAL CONSIDERATIONS FOR EXTREME WEATHER

If the unit is exposed to heavy wind: Install unit so that air outlet fan is at a 90° angle to the direction of the wind. If needed, build a barrier in front of the unit to protect it from extremely heavy winds. Ensure the wind barrier does not block necessary air flow. See Fig. 5.2 and Fig. 5.3 below.

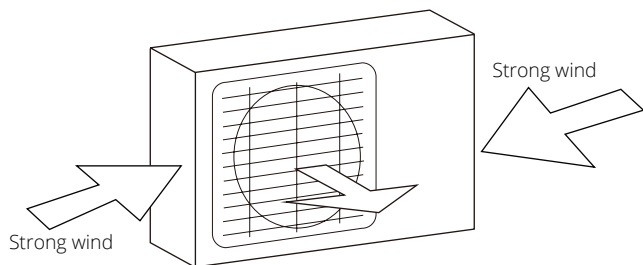

Fig. 5.2

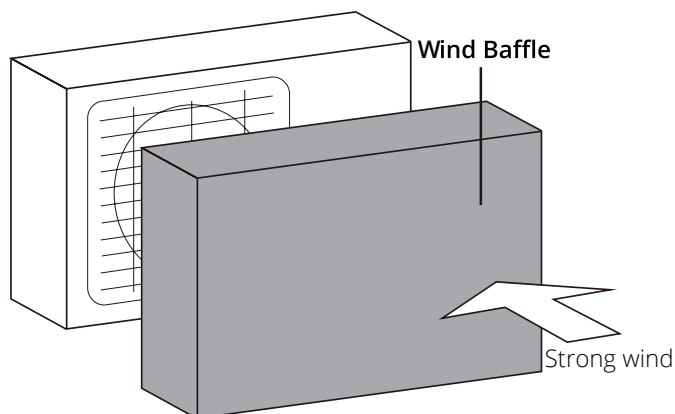

Fig. 5.3

If the unit is frequently exposed to heavy rain or snow:

Build a shelter above the unit to protect it from the rain or snow. Be careful not to obstruct air flow around the unit.

Step 2: Install drain joint

Heat pump units require a drain joint if the unit is elevated. Before bolting the outdoor unit in place, you must install the drain joint at the bottom of the unit. **NOTE:** there are two different types of drain joints depending on the type of outdoor unit.

If the drain joint comes with a rubber seal (see Fig. 5.4 - A), do the following:

1. Fit the rubber seal on the end of the drain joint that will connect to the outdoor unit.
2. Insert the drain joint into the hole in the base pan of the unit.
3. Rotate the drain joint 90° until it clicks in place facing the front of the unit.
4. Connect a drain hose extension (not included) to the drain joint to redirect water from the unit during heating mode.

If the drain joint does not come with a rubber seal (see Fig. 5.4 - B), do the following:

1. Insert the drain joint into the hole in the base pan of the unit. The drain joint will click in place.
2. Connect a drain hose extension (not included) to the drain joint to redirect water from the unit during heating mode.

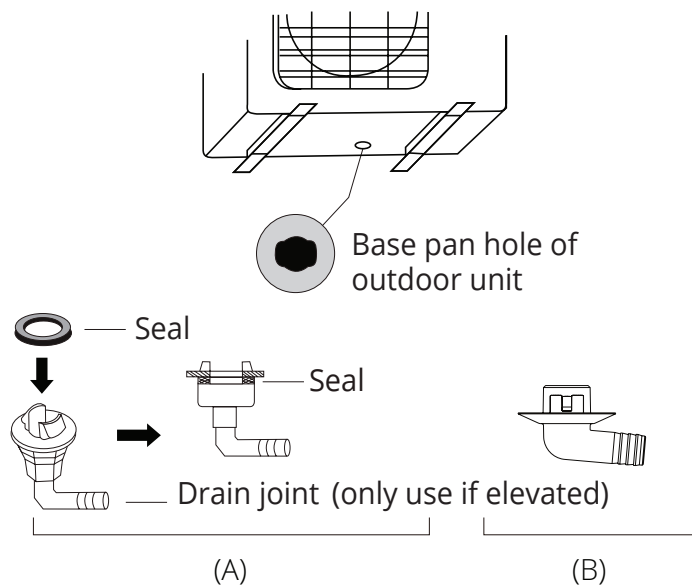

Fig. 5.4

! DRAINAGE IN COLD CLIMATES

In cold climates, make sure that the drain hose is as vertical as possible to ensure swift water drainage. If water drains too slowly, it can freeze.

Outdoor Unit Installation

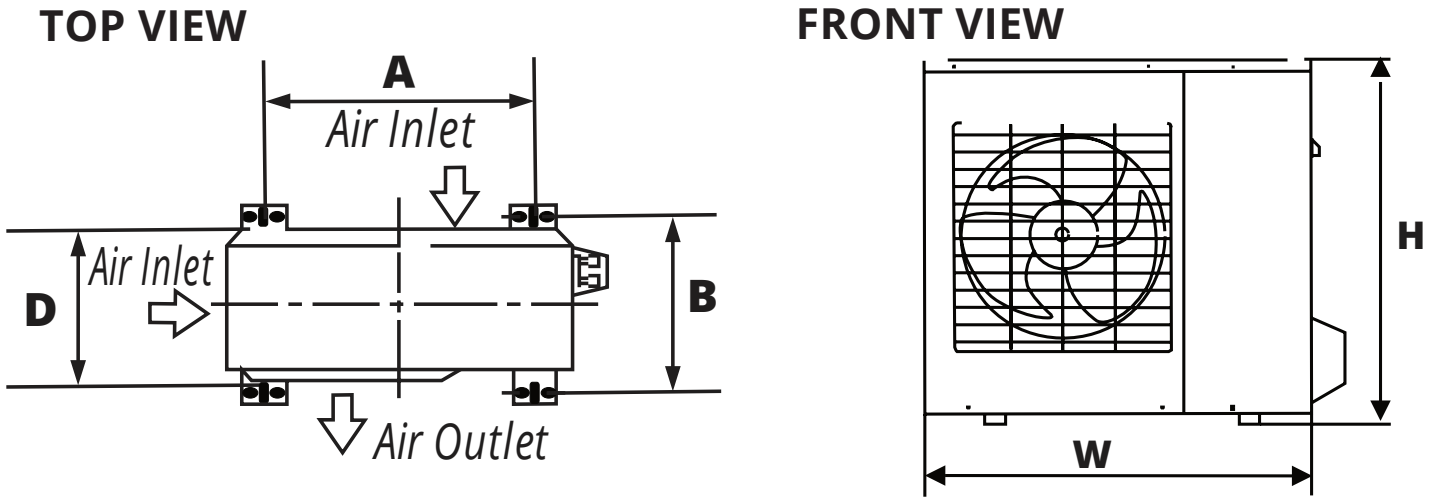

Fig. 5.5

UNIT MOUNTING DIMENSIONS

The following is a list of different outdoor unit sizes and the distance between their mounting feet. Prepare the installation base of the unit according to the dimensions in the table below, using the illustrations of the unit above (**Fig 5.5**) as a reference/guide to correspond with the table.

Outdoor Unit Dimensions: Inches (Millimeters) Width (W) x Height (H) x Depth (D)	Mounting Dimensions: Inches (Millimeters)	
	Width (A)	Depth (B)
DIY-12-HP-C-115B 31.5 in x 21.8 in x 13.1 in (800 mm x 554 mm x 333 mm)	20.24 in (514 mm)	13.39 in (340 mm)
DIY-18-HP-C-230B 33.25 in x 27.63 in x 14.29 in (845 mm x 702 mm x 363 mm)	21.26 in (540 mm)	13.80 in (350 mm)
DIY-24-HP-C-230B 37.21 in x 31.90 in x 16.53 in (946 mm x 810 mm x 420 mm)	26.5 in (673 mm)	15.87 in (403 mm)
DIY-36-HP-C-230B 37.21 in x 31.90 in x 16.53 in (946 mm x 810 mm x 420 mm)	26.5 in (673 mm)	15.87 in (403 mm)

If you are installing the outdoor unit on the ground, or a concrete mounting platform, use the following steps:

1. Mark the positions for four expansion bolts based on dimensions in the Unit Mounting Dimensions chart and illustrations above.
2. Pre-drill holes for expansion bolts.
3. Clean concrete dust away from holes.
4. Place a nut on the end of each expansion bolt.
5. Hammer expansion bolts into the pre-drilled holes.
6. Remove the nuts from expansion bolts, and place outdoor unit on bolts.
7. Put a washer on each of the expansion bolts, then reinstall the the nuts.
8. Using a wrench, tighten each nut until snug.

WARNING

WHEN DRILLING INTO CONCRETE, EYE PROTECTION IS RECOMMENDED AT ALL TIMES.

If you are installing the unit on a wall-mounted bracket, follow these steps:

! CAUTION

Before installing a wall-mounted unit, make sure that the wall is made of solid brick, concrete, or a similarly strong material. The wall must be able to support at least 4 times the weight of the unit.

1. Mark the position of bracket holes based on dimensions in the Unit Mounting Dimensions chart.
2. Pre-drill the holes for the expansion bolts.
3. Clean dust and debris away from holes.
4. Place a washer and nut on the end of each expansion bolt.
5. Thread expansion bolts through holes in mounting brackets, put mounting brackets in position, and hammer expansion bolts into the wall.
6. Check that the mounting brackets are level.
7. Carefully lift unit and place its mounting feet on the brackets.
8. Bolt the unit firmly to the brackets.

TO REDUCE VIBRATION OF WALL-MOUNTED UNIT

If allowed, you can install the wall-mounted unit with rubber gaskets to reduce vibration and noise.

Step 1: Prepare exterior wall hole

Before the refrigerant piping can be installed and connected to the indoor and outdoor units, some additional steps are required to prepare the exterior.

1. Install finishing ring/cap to exterior portion of the wall hole.



2. Place your hand on the underside of the piping coming through the exterior wall hole (from indoor unit), close to the wall. With your other hand, using even pressure, carefully bend the piping downward toward the wall, being mindful not to damage or dent the piping in the process.

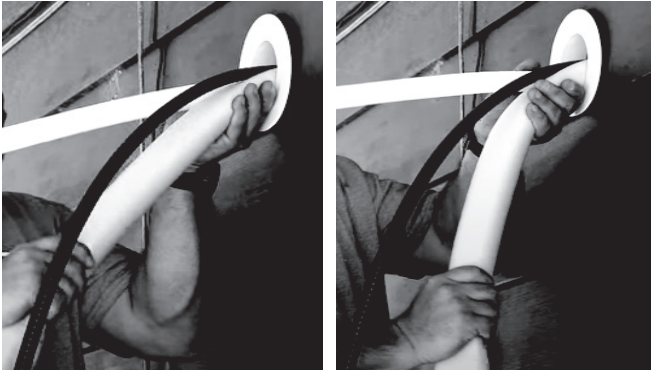

! CAUTION

Be extremely careful not to dent or damage the piping while bending it down the exterior wall, as this could negatively affect the performance.

3. Pack the wall hole with the supplied Neoprene (or Spray Foam can be used) to seal the hole, filling any space that was not taken up by the refrigerant piping and lines.

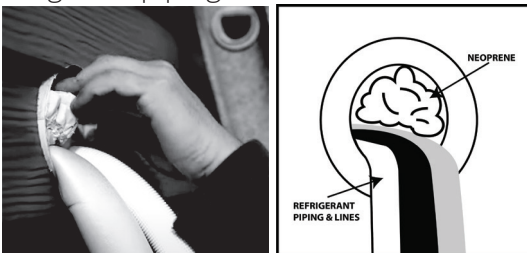

Step 2: Unwind Quick Connect® Line Set to necessary length

1. Use your hands to slowly unwind the copper piping of one end of the Quick Connect® Line Set. The end you unwind will connect to the indoor unit piping. Only unwind as much as necessary for your application, and allow any excess to remain coiled (Refer to **Fig. 6.1**).



MINIMUM BEND RADIUS

When bending connective refrigerant piping, it needs to have a minimum bend radius of 4 inches (Refer to Fig 6.1).

! CAUTION

If the pipe is repeatedly bent or extended, it will become hard and difficult to manipulate. Avoid bending or extending the pipe more than 3 times, or excessively, as it could break.

Fig. 6.1

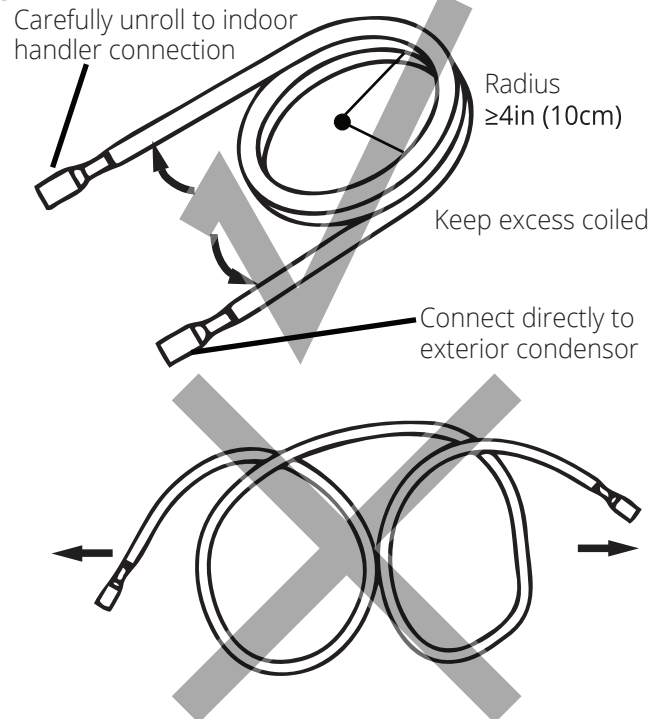

Refrigerant Piping Connection

Step 3: Connect Line Set to Indoor Unit

3.1 Tools needed

NOTE: Depending on the capacity rating of your unit, (12K, 18K, 24K, 36K) the wrench sizes needed will vary, refer to the table below (the unit uses metric sizes, the standard sizes listed are approximations). Based on the availability of wrenches in some of the sizes needed, the recommended method is to use crescent (adjustable-type) wrenches that can be adjusted to fit the size each step requires.

- Opened-ended wrench sizes needed (1x of each of these)

12K & 18K	24K & 36K
3/4" / 19 mm	3/4" / 19 mm
7/8" / 22 mm	15/16" / 24 mm
15/16" / 24 mm	1" / 26 mm
1" / 26 mm	1-1/8" / 29 mm
	1-1/4" / 31 mm

Or 2x Crescent (adjustable-type) Wrenches

- 1x HVAC Torque Wrench (if available)
- 1x Allen key, 5 mm
- 1x Phillips-head screwdriver
- 1x leak-detection spray or a soapy water solution (liquid detergent/mix, applied by brush or spray bottle)

3.2 IMPORTANT INFORMATION

PLEASE READ FULLY BEFORE PROCEEDING TO NEXT STEP

- Follow the detailed instructions for connecting the refrigerant pipes to the indoor unit and outdoor unit. We can only provide a warranty if the lines are installed correctly as described in the instructions.
- **DO NOT** remove the sealing caps and stoppers until immediately before you install the lines.
- To prevent leaks, ensure that the quick-release screw connections are absolutely free of dirt. Moisture or foreign bodies will adversely affect the function of the quick-release connectors, leading to a risk of refrigerant loss (not covered by the warranty).
- Only install refrigerant lines outdoors in dry weather.
- The refrigerant lines must not be plastered over after they are installed.
- Always wear work gloves and goggles and use caution when handling refrigerant. Please make sure that refrigerant is never allowed to enter the environment. Improper handling of refrigerant may be harmful to your health.
- **DO NOT** smoke during the installation work.
- The equipment must never be operated without the refrigerant lines connected, otherwise the equipment will be damaged immediately.
- The screw connections may only be tightened using the appropriate open-ended or crescent (adjustable-type) wrench.

Refrigerant Pipe Connectors (both ends):

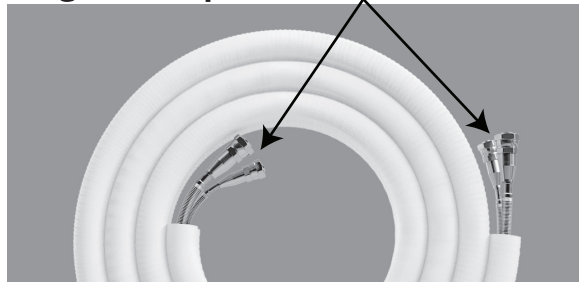

If the screw connections are tightened with too little torque, they will leak. If they are tightened with too much torque, the screw connections may suffer damage. Please refer to the torque requirements section for more information. If you are not confident about connecting the refrigerant line connectors yourself, it is imperative that you contact the MRCOOL® customer service team or a professional.

IMPORTANT:

The line sets are designed to only be installed once. The seal within the line set cannot be guaranteed if they are installed more than once. This will void the warranty. They also contain a compression fitting to seal and do not require a thread sealant (teflon tape, etc.). Using a sealant may actually cause the connection to leak over time.

3.3 Connecting the Quick Connect® Line Set to the piping from indoor unit

1. Do not remove the plastic seals of the piping coming from the indoor unit, or the appropriate line set connector, until immediately before you connect them. The plastic seals on each of the connectors should be color-coded to match the seals of the corresponding pipes they are to be connected to.
2. Align the refrigerant pipes correctly, making sure the dimensions of the connecting refrigerant pipe match. Unscrew the seals and place the screw connector of the line set pipe just onto the threads of the piping from the indoor unit, and tighten the first few threads by hand.

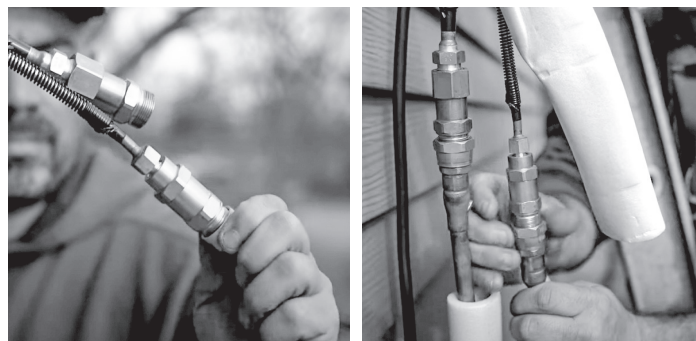

IMPORTANT:

Before you continue, it is essential that you read the following instructions fully and carefully.

! TORQUE REQUIREMENTS

1. Excessive force can break the nut or damage the refrigerant piping. You must not exceed torque requirements shown in the table below.
2. You can find the Outer Pipe Diameter stamped (in inches) on the valve set of the condenser. Refer to this when finding and applying the torque values in the table below.
3. Note that there may be differences in Torque Wrenches (i.e. automotive torque wrench versus a HVAC torque wrench) and that a socket style wrench cannot be used here.

NOTE: Torque ratings in the table below are to be used if you have access to an HVAC torque wrench. These are available for purchase from online retailers. However, it is possible to complete installation of refrigerant line sets with conventional open-ended/crescent wrenches. It is imperative, however, that you not overtighten the connector, and that once the lines have been fully connected, you follow the steps to check for leaks. If you do not feel comfortable attempting this, please contact a qualified HVAC technician.

3. Using the image below as a guide, and the steps outlined in this paragraph, you will now tighten the nuts of the screw connectors of the Quick Connect® Line Set to the indoor unit. Using two appropriate sized open-ended wrenches (depending on the dimensions of the connector) or adjustable crescent wrenches, place one of the wrenches on the nut marked "1", and the other wrench on the nut marked "2," as shown in the image below. Now, turn the wrench marked "2" in the direction of the rotational arrows, as shown, while holding the other wrench in place. Continue to tighten the connector until snug. **NOTE: work quickly and make sure the screw connectors do not become crooked as you tighten them.**

***If an HVAC torque wrench is available:** Once the connector is snug, using the torque wrench, tighten the connector to the specified torque rating, listed in the table above (based on the pipe size).

***If an HVAC torque wrench is NOT available:** Using the two wrenches you used to tighten the connector, once the connector is snug, turn the wrench slightly beyond that point to torque the connector, but do not overtighten it.

4. Repeat the same process for the second line.

Stamp	Outer Pipe Diameter inch (millimeter)	Maximum Tightening Torque lb·ft (N·m)
1/4"	0.25 in (6.35 mm)	11.8 lb·ft (16 N·m)
3/8"	0.375 in (9.52 mm)	19.18 lb·ft (26 N·m)
1/2"	0.5 in (12.7 mm)	26.55 lb·ft (36 N·m)
5/8"	0.63 in (16 mm)	34.67 lb·ft (47.01 N·m)

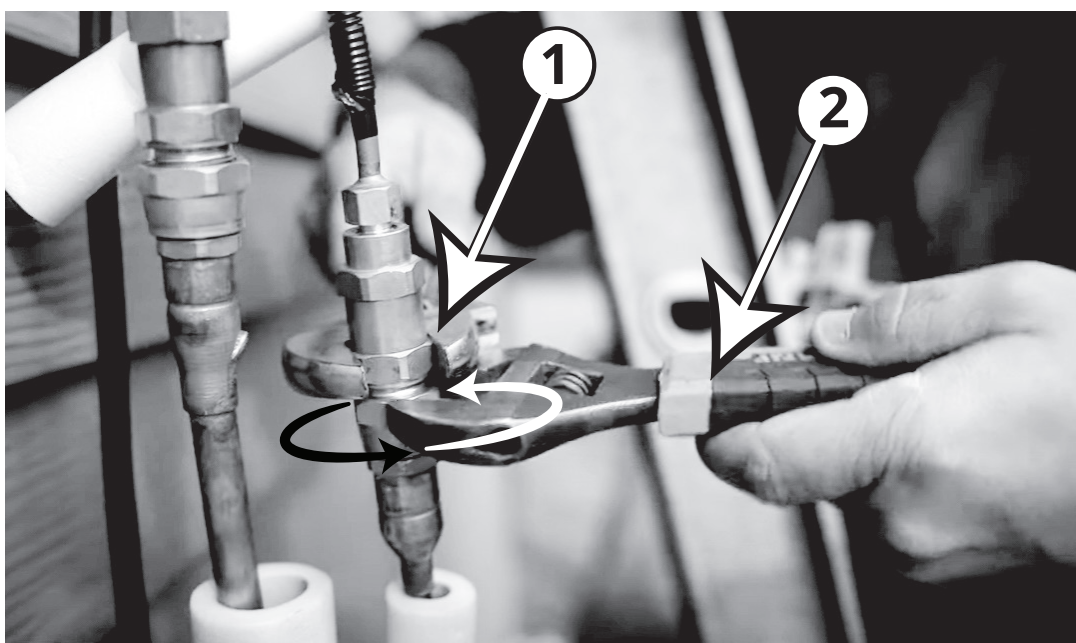

! CAUTION

For your safety, always wear goggles and work gloves when connecting the pipes.

Step 4: Connect Line Set to the Outdoor Unit

1. First remove the water tray on the outdoor unit as shown in the illustration.

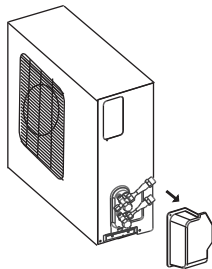

2. Do not remove the plastic seals from the outdoor unit piping connectors and corresponding refrigerant pipes (line set to be attached) until immediately before you connect them.

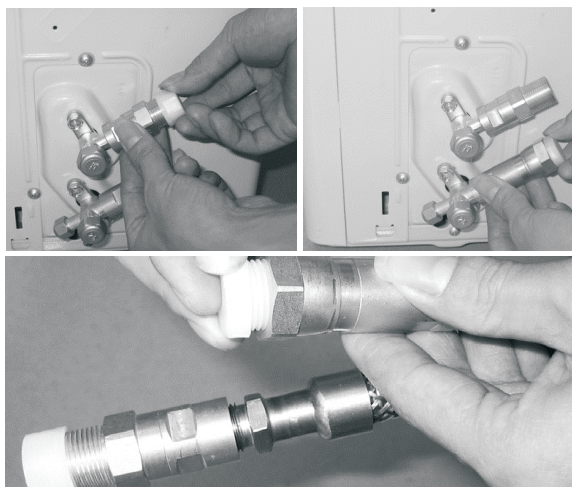

NOTE: Ensure the adapters attached to the outdoor valves have been tightened properly before attempting to connect the line set.

3. Align the refrigerant pipes so they line up with the corresponding valves and have enough slack. **NOTE: The refrigerant pipes must be connected to the valves with as little stress as possible.** Unscrew the plastic seals and place the screw connector of the refrigerant line just onto the threads of the outdoor unit, tightening the first few threads by hand.

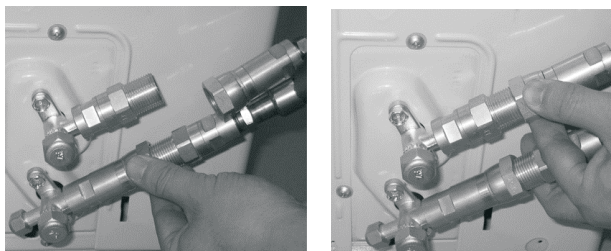

IMPORTANT:

Before you continue, it is essential that you read the following instructions carefully.

4. Using the first image below as a guide, starting with the bottom screw connector, you will now tighten the line set to the outdoor unit. Using two appropriate sized open-ended wrenches (depending on the dimensions of the connector), or adjustable crescent wrenches, place one of the wrenches on the nut marked "1", and the other wrench on the nut marked "2." Now, turn the wrench on nut "2" in the direction of the rotational arrow, while holding the other wrench in place, as seen in the first image below. Continue to tighten the connector until snug. **NOTE: work quickly and make sure the screw connectors do not become crooked as you tighten them.**

***If an HVAC torque wrench is available:** Once the connector is snug, using the torque wrench, tighten the connector to the specified torque rating, listed in the table on the next page (based on the pipe size).

***If an HVAC torque wrench is NOT available:** Using the two wrenches you used to tighten the connector, once the connector is snug, then turn the wrench slightly beyond that point to torque the connector, but do not overtighten it.

5. Repeat the same process for the top screw connector, using the second image below as a guide.

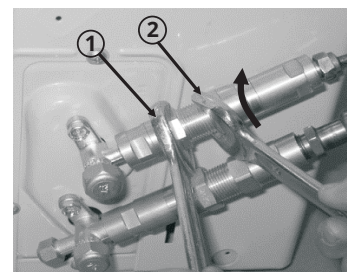
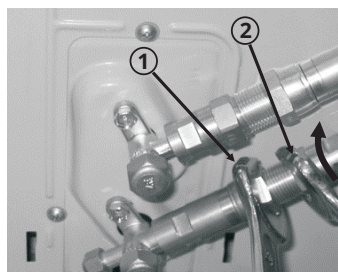

! IMPORTANT

The coupling of the outdoor unit uses tapping rings, if you disconnect and reconnect the refrigerant pipes, it could cause it to leak. This will also void the warranty.

NOTE:

Keep excess refrigerant hose coiled. Wrap with protective tape and store behind the condenser in a horizontal position (flat with the ground).

TORQUE REQUIREMENTS

1. Excessive force can break the nut or damage the refrigerant piping. You must not exceed torque requirements shown in the table below.

2. You can find the Outer Pipe Diameter stamped (in inches) on the valve set of the condenser. Refer to this when finding and applying the torque values in the table below.

3. Note that there may be differences in Torque Wrenches (i.e. automotive torque wrench versus a HVAC torque wrench) and that a socket style wrench cannot be used here.

NOTE: Torque ratings in the table below are to be used if you have access to an HVAC torque wrench. These are available for purchase from online retailers. However, it is possible to complete installation of refrigerant line sets with conventional open-ended/crescent wrenches. It is imperative, however, that you not overtighten the connector, and that once the lines have been fully connected, and the valves have been opened, you follow the steps to check the pipe connections for leaks (Refer to the Electrical & Gas Leak Checks section of this manual for more information) . If you do not feel comfortable attempting this, please contact a qualified HVAC technician.

Stamp	Outer Diameter of Pipe inch (millimeter)	Tightening Torque lb·ft (N·m)	Add. Tightening Torque lb·ft (N·m)
1/4"	0.25 in (6.35mm)	11 lb·ft (14.91 N·m)	11.8lb·ft (16 N·m)
3/8"	0.375 in (9.52 mm)	18.4 lb·ft (24.95 N·m)	19.18lb·ft (26 N·m)
1/2"	0.5 in (12.7 mm)	25.8 lb·ft (34.98 N·m)	26.55lb·ft (36 N·m)
5/8"	0.63 in (16 mm)	33.19 lb·ft (45 N·m)	34.67lb·ft (47.01N·m)

Refrigerant Piping Connection

Step 5: Opening the refrigerant valves of the outdoor unit

1. Using the images below as a guide, remove the cover on the top valve, using a 19 mm open-ended wrench or a crescent (adjustable-type) wrench. Then, insert a 5 mm Allen key and open the valve by turning it counter-clockwise as far as it will go. **DO NOT force it.** The valve is now open. Screw the cover back onto the top valve and tighten it well to ensure that it is properly sealed.
2. Using the images below as a guide, repeat the same process for the bottom valve. Remove the cover on the bottom valve, using a 19 mm open-ended wrench or a crescent (adjustable-type) wrench. Then, insert a 5 mm Allen key and open the valve by turning it counter-clockwise as far as it will go. **DO NOT force it.** Screw the cover back onto the bottom valve and tighten it well to ensure that it is properly sealed.

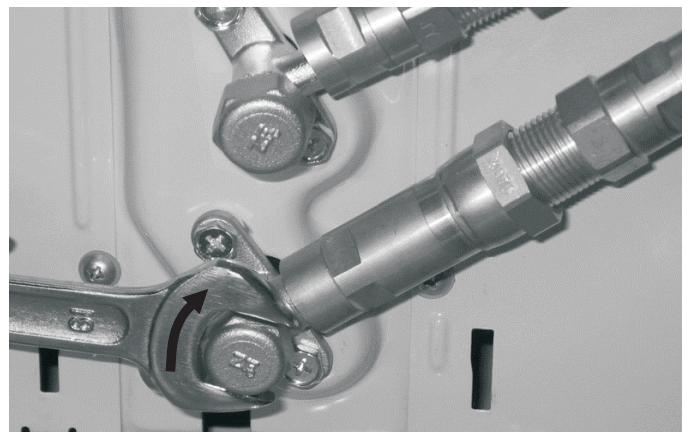
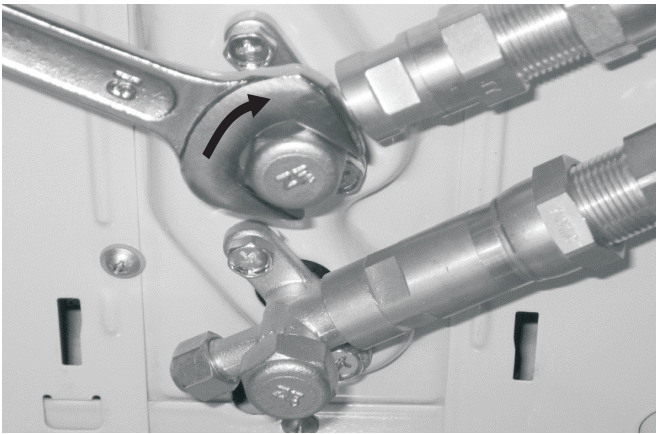
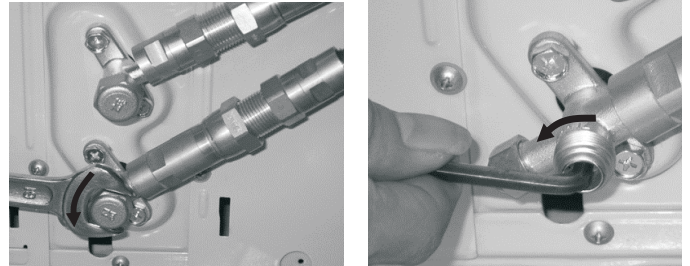
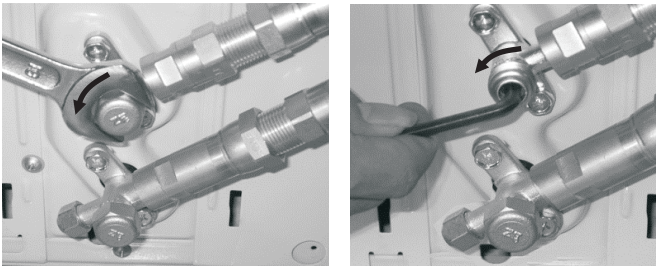

! CAUTION

If the valves are not fully opened, it could cause the system to malfunction and suffer damage.

3. After completing steps 1 and 2, you will now need to check all of the piping connections (at indoor unit and outdoor unit) for leaks. You can do this by using leak detection spray, or applying a soapy water solution (liquid detergent/water mixture) to the connection via a spray bottle or brush. If any bubbles begin to form, that indicates there is a leak, and the connection needs to be retightened. Tighten the connection and recheck it for leaks. Refer to **Electrical and Gas Leaks Checks** section of this manual for more information.



IMPORTANT:

You will be asked to check for leaks at the piping connections multiple times throughout the following steps of the installation, because the pressures within the lines will change once the unit is turned on and this could reveal leaks not present during the initial check. These are imperative to make sure your connections are not allowing refrigerant to escape the system. When checking for leaks, if any bubbles form, it indicates the system has a leak and the screw connector needs to be retightened. For more information about checking for leaks, please refer to the **Electrical and Gas Leak Checks** section of the manual.

Refrigerant Piping Connection

Step 6: Connect Drain Pipe

In this step you will connect the drain hose extension to the drain hose exiting from the indoor unit piping

1. Securely connect the drain hose extension to the drain piping from the indoor unit.

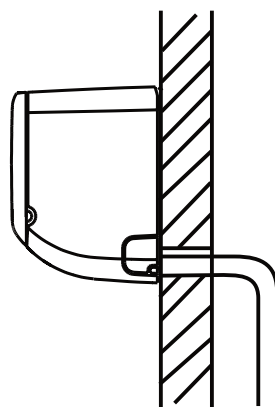
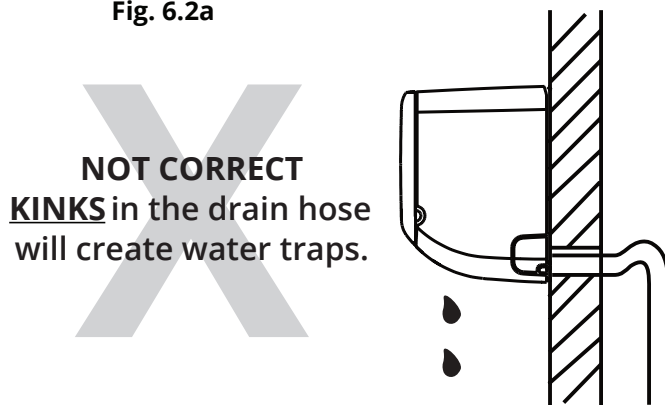

Fig. 6.2a

Make sure there are **NO** kinks or dents in the hose to ensure proper drainage.



NOT CORRECT
KINKS in the drain hose will create water traps.

Fig. 6.2b

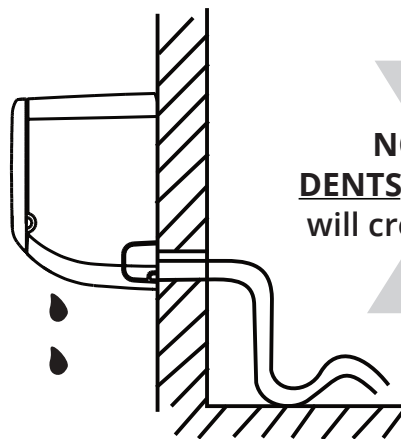

NOT CORRECT
DENTS in the drain hose will create water traps.

Fig. 6.2c

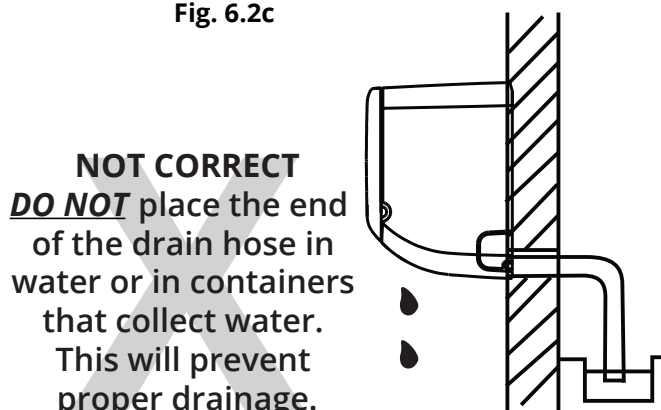

NOT CORRECT
DO NOT place the end of the drain hose in water or in containers that collect water. This will prevent proper drainage.

Fig. 6.2d

2. Using example **Fig. 6.2a** as a guide, make sure your drain pipe is run in a similar manner. The other examples in **Fig 6.2** represent things you should avoid when installing your drain pipe.
3. Remove the air filter from the indoor unit and pour a small amount of water into the drain pan to ensure that the water exits the bottom of the unit and flows through the drain and drain pipe smoothly.

NOTE ON DRAIN HOSE PLACEMENT

! CAUTION

Make sure to arrange the drain hose correctly according to Fig. 6.2a.

- ⊘ **DO NOT** kink the drain hose.
- ⊘ **DO NOT** create a water trap.
- ⊘ **DO NOT** put the end of drain hose in water or a container that will collect water.

ENSURE UNUSED DRAIN HOLE IS PLUGGED

To prevent unwanted leaks, be sure that the factory installed hollow center rubber plug is installed in the unused drain hole.

Refrigerant Piping Connection

Step 7: Wrap piping connections

In this step you will insulate the exposed line connections coming from the indoor air handler with the supplied sound deadening pads and insulation. Then wrap the line set from the outdoor unit to the wall hole with the supplied Non-Adhesive U.V. Tape.

IMPORTANT

Do not complete these steps until all of the refrigerant piping connections have been checked for leaks.

1. Wrap the connectors at the indoor air handler tightly with the supplied sound deadening pads.



2. Now, place the supplied insulation material over the connectors and exposed refrigerant piping

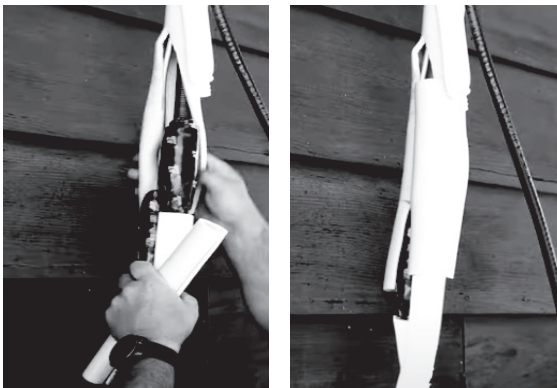

3. Now, starting at the outdoor condenser and working your way up to the wall hole, you will wrap the exposed line set, cables, and drain hose together tightly using the supplied Non-adhesive U.V. tape. The drain pipe will need to be at the bottom of the bundle (**Refer to Fig. 6.3 and the image below**). ***DO NOT*** wrap the end of the drain hose

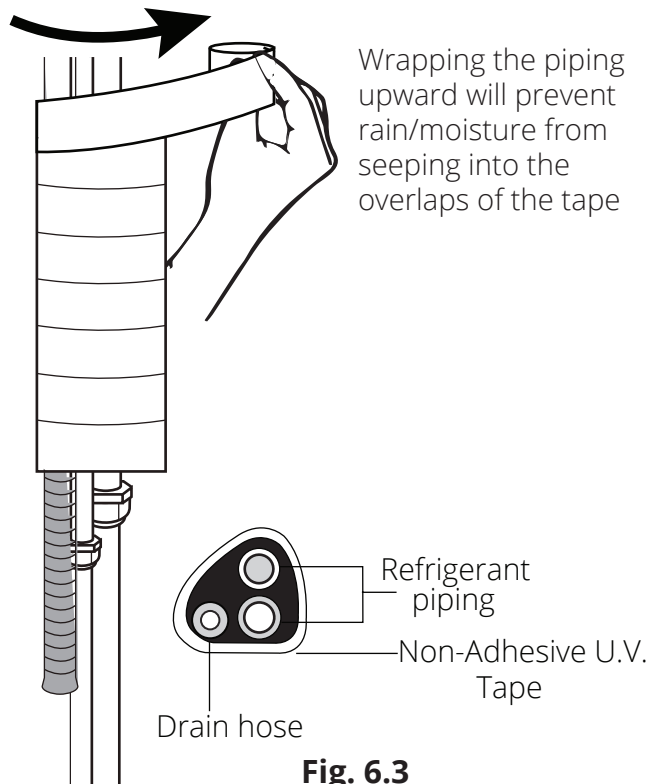

Fig. 6.3

If you would like the exterior piping on the side of your home to have a sleeker, more attractive look and add some extra protection in the process, you can purchase a **MRCOOL LineGuard® Line Set Cover**. This will encase your refrigerant piping and lines, protecting them from harsh weather conditions and sun exposure, which will extend the life of your system. These covers are available in various sizes to fit your particular application.



Refrigerant Piping Connection

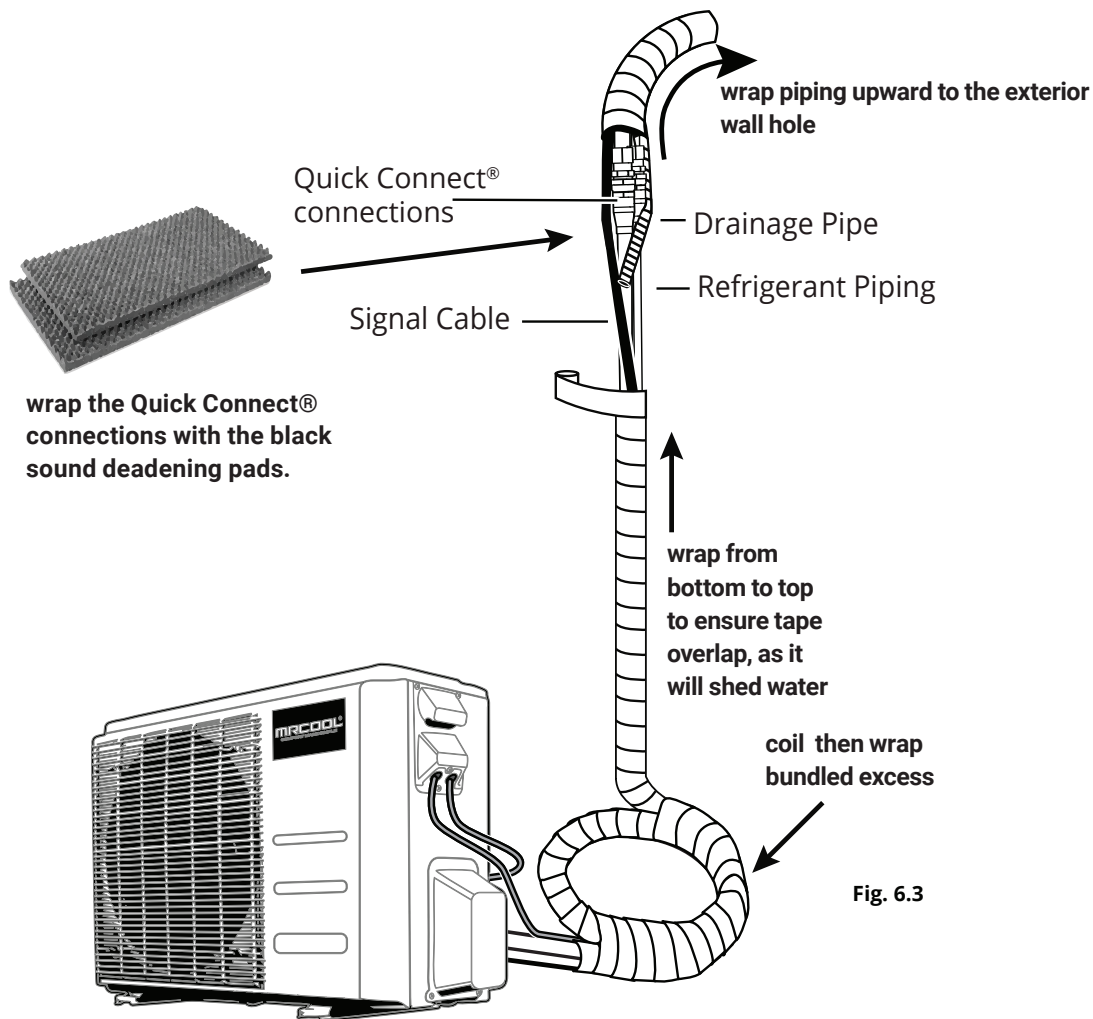

Fig. 6.3

Outdoor Unit (Exterior / Condenser)



BEFORE PERFORMING ELECTRICAL WORK, READ THESE REGULATIONS

1. All wiring must comply with local and national electrical codes.
2. All electrical connections must be made according to the **Electrical Connection Diagram** located on the panels of both the indoor and outdoor units.
3. If there is a serious safety issue with the power supply, stop work immediately. Explain your to the client, and refuse to install the unit until the safety issue is properly resolved.
4. Power voltage should be within 90-100% of rated voltage. Insufficient power supply can cause malfunction, electrical shock, or fire.
5. Circuit, including any switches, should have a capacity 1.5 times the maximum unit current (amps).
6. A qualified technician must use an approved circuit breaker or switch that disconnects all poles and has a contact separation of at least 1/8 in (3 mm).
7. Do not connect another appliance to the same circuit as the unit.
8. Make sure to properly ground the unit.
9. Every wire must be firmly connected. Loose wiring can cause the terminal to overheat, resulting in malfunction and possible fire.
10. Do not allow wires to touch or rest against the refrigerant tubing, compressor, or any other moving part within the unit.
11. If the unit has an auxiliary electric heater, it must be installed at least 40 in (1 meter) away from combustible materials.

Connect signal and power cables

The outside unit's terminal block is protected by an electrical wiring cover on the side of the unit.

A comprehensive wiring diagram is printed on the inside of the wiring cover.

WARNING

BEFORE PERFORMING ANY ELECTRICAL WORK, TURN OFF ALL POWER TO THE SYSTEM.

Note that wire colors of this series / model may differ from previous models, other series and general conventions. All wiring must be performed in accordance with the wiring diagrams shown in Fig. 7.1 and demonstrated in the images below.

WIRE CONNECTING DIAGRAM (12K Unit Only)

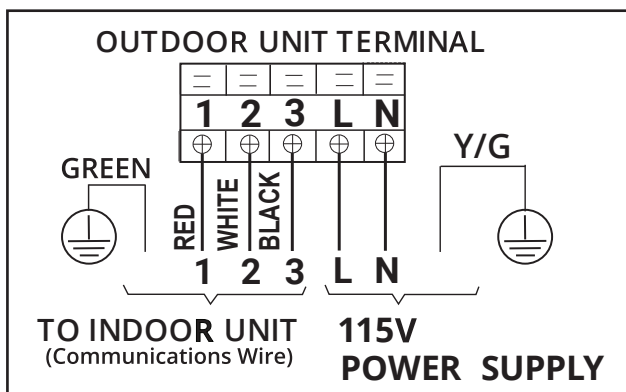

WIRE CONNECTING DIAGRAM (All Other Units)

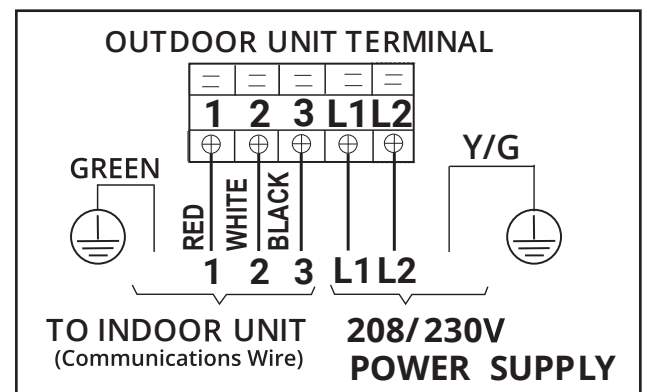

Fig. 7.1

WARNING

DO NOT MIX UP LIVE AND NULL WIRES

This is dangerous and can cause the air conditioning unit to malfunction. Make sure you clearly distinguish the Live ("L") Wires from the other wires.

All wiring must be performed in accordance with the wiring diagrams shown in Fig. 7.1 and demonstrated in the images shown here.

WIRES AND TERMINALS ARE NUMBERED TO CORRESPOND WITH ONE ANOTHER AS SHOWN BELOW.

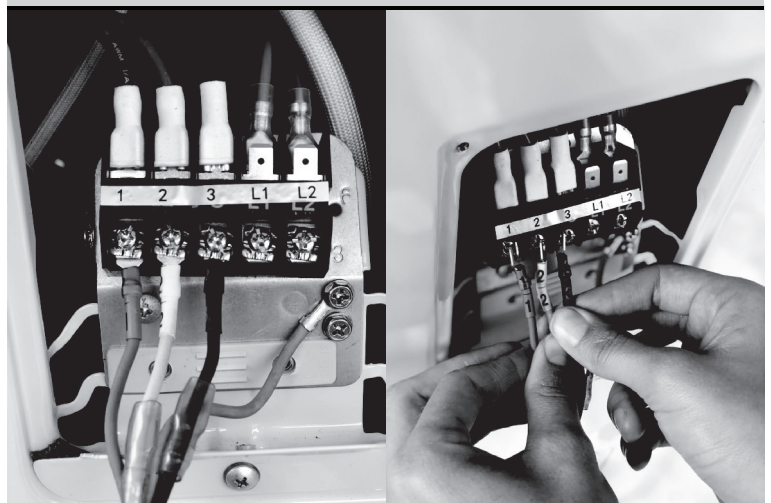

1. Prepare the cable for connection:

SELECT THE CORRECT CABLE

- See table below for gauge requirements

Minimum Wire Gauge for Power Cables

Model Series	Appliance Amps (A)		AWG	
	MOP	MCA	Min.	Pref.
9K & 12K	20	15	14	12
18K	20	15	14	12
24K	30	18	14	12
36K	40	25	12	10

WARNING

ALL WIRING MUST BE INSTALLED STRICTLY IN ACCORDANCE WITH THE WIRING DIAGRAM LOCATED AS SHOWN IN FIG 7.2.

2. Unscrew the electrical wiring cover and remove it.
3. Unscrew the cable clamp below the terminal block and place it to the side.
4. Match the wire colors / labels with the labels on the terminal block, and firmly screw the u-lug of each wire to its corresponding terminal.
5. After checking to make sure every connection is secure, loop the wires around to prevent rain water from flowing into the terminal.
6. Using the cable clamp, fasten the cable to the unit. Screw the cable clamp down tightly.
7. Insulate unused wires with PVC electrical tape. Arrange them so that they do not touch any electrical or metal parts.
8. Replace the wire cover on the side of the unit, and screw it in place.

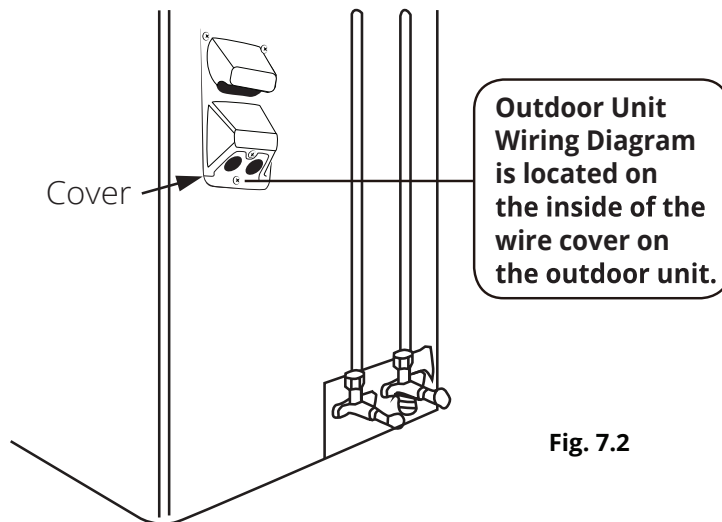

Fig. 7.2

NOTE ABOUT FUSE SPECIFICATIONS

The air conditioner's circuit board (PCB) is designed with a fuse to provide overcurrent protection. The specifications of the fuse are printed on the circuit board.

EXAMPLE Indoor unit: T3.15AL/250VAC, T5AL/250VAC, T3.15A/250VAC, T5A/250VAC, etc.

EXAMPLE Outdoor unit:
T20A/250VAC(≤ 18000 Btu/h units),
T30A/250VAC(> 18000 Btu/h units), etc.

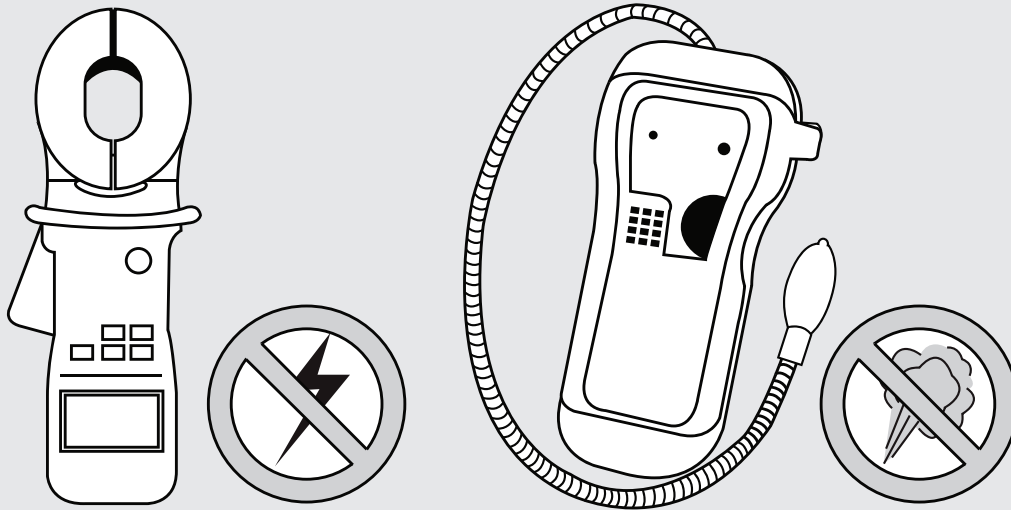

Electrical Safety Checks

After installation, confirm that all electrical wiring is installed in accordance with local and national regulations, and according to the Installation Manual.

BEFORE TEST RUN

Check Grounding Work

Measure grounding resistance by visual detection and with grounding resistance tester. Grounding resistance must be less than 4.

NOTE: This may not be required for some locations in the US.

DURING TEST RUN

Check for Electrical Leakage

During the Test Run, use an electroprobe and multimeter to perform a comprehensive electrical leakage test.

IF ELECTRICAL LEAKAGE IS DETECTED

If electrical leakage is detected, turn off the unit immediately and call a licensed electrician to find and resolve the cause of the leakage.

NOTE: This may not be required for some locations in the US.



WARNING – RISK OF ELECTRIC SHOCK

ALL WIRING MUST BE INSTALLED BY A LICENSED ELECTRICIAN AND COMPLY WITH LOCAL, STATE, AND NATIONAL ELECTRICAL CODES.

Gas Leak Checks

There are two different methods to check for gaseous leaks.

Soap and Water Method

Using a soft brush or spray bottle, apply a soapy water solution to all of the pipe connection points of the indoor and outdoor units, watching to see if any bubbles form. The presence of bubbles indicates there is a leak.

Leak Detector Method

If using a leak detector, refer to the device's operation/instruction manual for proper usage instructions.

AFTER PERFORMING GAS LEAK CHECKS

After confirming that all the pipe connection points DO NOT leak, replace the valve cover on the outside unit and wrap and insulate the piping connections of the indoor unit.

Before Test Run

Only perform test run after you have completed the following steps:

- **Electrical Safety Checks** – Confirm that the electrical system is safe and operating properly
- **Gas Leak Checks** – Check all flare nut connections and confirm that the system is not leaking
- Confirm that gas and liquid (high and low pressure) valves are fully open

Test Run Instructions

You should perform the Test Run for at least 30 minutes.

1. Connect power to the unit.
2. Press the ON/OFF button on the remote controller to turn it on.
3. Press the MODE button to scroll through the following functions, one at a time:
 - **COOL** – Select lowest possible temperature
 - **HEAT** – Select highest possible temperature
4. Let each function run for 5 minutes, and perform the following checks:

List of Checks to Perform	PASS/FAIL	
No electrical leakage		
Unit is properly grounded		
All electrical terminals properly covered		
Indoor and outdoor units are solidly installed		
Wall Penetration Sleeve is packed airtight		
All pipe connection points do not leak	Outdoor (2):	Indoor (2):
Water drains properly from drain hose		
All piping is properly insulated		
Unit performs COOL function properly		
Unit performs HEAT function properly		
Indoor unit louvers rotate properly		
Indoor unit responds to remote control		

DOUBLE-CHECK PIPE CONNECTIONS

During operation, the pressure of the refrigerant circuit/piping will increase. This may reveal leaks that were not present during your initial leak check. Take time during the Test Run to double-check that all refrigerant pipe connection points do not have leaks. Refer to **Gas Leak Check** section for instructions.

5. After the Test Run is successfully complete, and you confirm all check points in List of Checks to Perform have PASSED, do the following:
 - a. Using remote control, return unit to normal operating temperature.
 - b. Using insulation tape, wrap the indoor refrigerant pipe connections that you left uncovered during the indoor unit installation process.

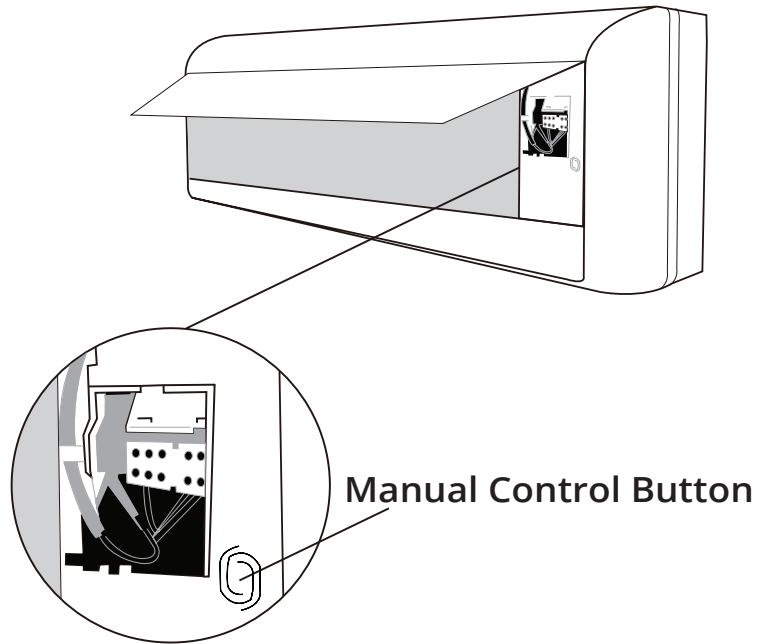

Fig. 9.1

IF AMBIENT TEMPERATURE IS BELOW 63°F (17°C)

If the ambient temperature is below 63°F (17°C), the remote controller cannot be used to turn on the COOL function. In this instance, you will need to use the **MANUAL CONTROL BUTTON** to test the COOL function. Follow the steps below to access this function:

1. Lift the front panel of the indoor unit, and continue to raise it until it clicks into place and becomes self-supporting.
2. The **MANUAL CONTROL BUTTON** is located on the right-hand side of the unit (Refer to Fig 9.1). Press it 2 times to select the COOL function.
3. Perform Test Run as normal.

! THANK YOU

Thank you for purchasing a MRCOOL ductless mini-split heating and air conditioning product.

MRCOOL is a young, family-owned company, so we are truly thankful you trusted us with your business. Should you ever need technical support, or just have questions about your MRCOOL product, or any of the other products we offer, please do not hesitate to call us at (270)-366-0457.

Also, if you can spare a few minutes today, and leave a review of your new MRCOOL® product on the partner site where you purchased it, it would really mean a lot to us. We are always looking for ways to improve, and real reviews, from actual customers like yourself, are vital and invaluable to our growing company.

Thank you for being a valued customer!

The following events may occur during normal operation, and may not indicate a malfunction.

Symptom	Cause
Operation is delayed after restart	The protection circuit will prevent the compressor from operating for roughly 3 minutes, after a sudden ON-OFF operation of the power supply, in order to prevent a blowout of the fuse.
Fan speed changes - off, very slow and then normal	Automatically happens in heating mode : --prevents cold air blowing onto occupants when heating operation starts --perform automatic defrosting operation --perform low temperature heating operation
Heating operation stops suddenly and defrost-light blinks	In HEAT mode, the indoor unit temporarily stops for a maximum of 10 minutes to perform the automatic defrosting operation.
Mist coming out of the indoor unit	In COOL mode, a mist generated by condensation formed with sudden cooling process may be emitted.
	Mist may generate due to moisture from defrosting process when the air conditioner restarts in HEAT mode operation after defrosting.
Low volume sounds are emitted by the air conditioner	Hissing sound -- during operation or immediately after stopping the air conditioner, refrigerant flowing sound may be heard.
	Squeaking sound -- normal expansion and contraction of plastic and metal parts caused by temperature change during the operation.
	Rushing air -- when louver resets its position.
Dust discharges from the unit	May occur when air conditioner is used for the first time or has not been used for a long time.
Emits a peculiar odor	Various smells generated from interior textile, furniture, or cigarette smoke absorbed into the air conditioner may be emitted. If not the case, contact a local dealer or your installation contractor.
Changes to fan only while cooling or heating mode	Room temperature reaches the temperature setting of the remote control. If not the case, contact a local dealer or your installation contractor.
Operation is erratic, unpredictable or unresponsive	Interference from cell phone towers and remote boosters may cause the unit to malfunction.
	Turn power off at the unit and at the circuit breaker, wait 10 seconds and turn power back on
	Press the ON/OFF button on the remote controller to restart operation.

NOTE: If the problem is not resolved, please contact a qualified service professional. Be sure to inform them of the detailed malfunctions and unit model number.

Troubleshooting

Before you call to request service assistance, troubleshoot a problem by performing the following checks:

Symptom	Diagnostic
Unit will not operate	-- Is there a power failure?
	-- Has a switch been turned off, a circuit breaker tripped or a fuse blown?
	-- Is the timer operating?
	-- Are the batteries used in the remote controller exhausted?
	-- Are the batteries used in the remote controller installed properly?
Poor cooling or heating performance	-- Are the air filters dirty?
	-- Is air flow unrestricted in & out of indoor & outdoor units?
	-- Are the temperature and mode settings correct?
	-- Are the windows or doors left opened?
	-- Is fan speed on high and louvers allowing maximum flow?
	-- Is direct or strong sunlight shining into the room in cooling operation?
	-- Are there other heat generating devices (such as a computers operating), or too many people in the room in cooling operation?
-- Is the SILENCE function activated? Under SILENCE operation, noise reduction is prioritized and the air-conditioning performance may become lower.	
Indicator lamps continue flashing	-- The unit may stop operation or continue to run in a safety condition (depending on the model). The fault may be recovered automatically by waiting for about 10 minutes. If this does not resolve the fault, disconnect the power and then reconnect it. If the problem still exists after the power has been restored, disconnect the power and contact the nearest customer service center. NOTE: The wire colors of this series/model may differ from that of previous models, other series, and general wiring conventions. All wiring must be performed in accordance with the wiring diagrams, shown in Section 7 (Refer to Fig. 7.1), and associated images. Wires and terminals are numbered to match accordingly.
Errorcode appears in the indoor unit, such as: E0,E1,E2.... P1,P2,P3..... or F1, F2,F3.....	

NOTE: If the problem is not resolved, please contact a qualified service professional. Be sure to inform them of the detailed malfunctions and unit model number.



WARNING

In the case of ANY of the following, turn off the unit immediately!

- Signal/power cable is damaged or abnormally warm
- Burning odor
- Loud or abnormal sounds
- A power fuse or circuit breaker trips frequently
- Water or other objects fall into or out of the unit

DO NOT ATTEMPT TO CORRECT THESE ITEMS YOURSELF!

CONTACT A SERVICE PROFESSIONAL IMMEDIATELY

Indoor Unit Error Display

O (light)

X (off)

☒ (flash)

Operation LED	Timer LED	Display	LED STATUS
☒ 1 time	X	E0	Indoor unit EEPROM parameter error
☒ 2 times	X	E1	Indoor / outdoor units communication error **
☒ 3 times	X	E2	Zero-crossing signal detection error
☒ 4 times	X	E3/E88	Indoor fan speed has been out of control
☒ 5 times	X	E4	Indoor room temperature sensor T1 open circuit or short circuit
☒ 6 times	X	E5	Evaporator coil temperature sensor T2 open circuit or short circuit
☒ 7 times	X	EC	Refrigerant leakage detection
☒ 2 times	O	F1	Outdoor ambient temperature sensor T4 open circuit or short circuit
☒ 3 times	O	F2	Condenser coil temperature sensor T3 open circuit or short circuit
☒ 4 times	O	F3	Compressor discharge temperature sensor T5 open circuit or short circuit
☒ 5 times	O	F4	Outdoor unit EEPROM parameter error
☒ 6 times	O	F5	Outdoor fan speed has been out of control
☒ 1 time	☒	P0	IPM malfunction or IGBT over-strong current protection
☒ 2 times	☒	P1	Over voltage or over low voltage protection
☒ 3 times	☒	P2	High temperature protection of compressor top diagnosis and solution (only for 9k, 12k models)
☒ 5 times	☒	P4	Inverter compressor drive error
X	X	P6	Discharge temp sensor
X	X	P7	USB Smart Controller module not installed

** Note that the wire colors of this series / model may differ from previous models, other series and general conventions. All wiring must be performed in accordance with the wiring diagrams shown in Section 7 Fig. 7.1 and associated images. Wires and terminals are numbered to match accordingly.



MRCOOL®

COMFORT MADE SIMPLE

DIY® E Star™ Series

The design and specifications of this product and/or manual are subject to change without prior notice. Consult with the sales agency or manufacturer for details.