

## PERFORMANCE

°F   %RH	<b>80   60</b>	<b>75   50</b>
Water Removal (P/Day)	746	530
Efficiency (P/kWh)	7.3	5.0
Energy Factor (L/kWh)	3.5	2.4

## ELECTRICAL

°F   %RH	<b>80   60</b>
Supply Voltage	480V
Current Draw	6.5A
Recommended Breaker Size	15A
Power	4,300W
Power Cord	Hardwire, no cord
CFM	1,750
BTU (Total)	48,400
BTU (Heat of Condensation)	33,900
BTU (Motor Load)	14,500

## SPECS

Control Type	External control required (not provided)
Refrigerant Type	R410a
Refrigerant Amount	6 lb 7 oz
Weight	340 lb
Air Filter MERV Rating	MERV-13
Dimensions	18" x 20" x 2"
Drain Port Connection	3/4" Threaded NPT
Operating Temperature	56 F Min. -95 F Max.



## DIMENSIONS

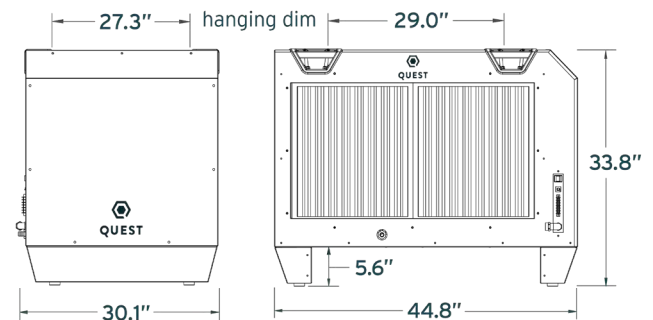

## FEATURES

- + **Patented Coil Technology:** Achieves the highest efficiency in its class
- + **Superior MERV-13 filtration:** Removes harmful contaminants from the air, such as mold, bacteria, and virus carriers
- + **Integrated handles and hanging points** for easier movement and installation
- + **Low amp draw,** freeing up electricity for other equipment
- + **Auto-restart** after loss of power

Specifications are subject to change without notice. Drawings are not to scale.