

USER MANUAL

# PHANTOM DE

DOUBLE ENDED LIGHTING SYSTEMS (ALL MODELS)



OPEN, ENCLOSED AND SUPER DEEP SYSTEMS

 **HYDROFARM**

**PARsource**

## GENERAL OVERVIEW

Thank you for purchasing the Phantom Double-Ended Lighting System. Setup is the same for each system: Open, Enclosed and Super Deep.

**⚠ WARNING:** FAILURE TO FOLLOW OUR GUIDELINES COULD RESULT IN ELECTRICAL SHOCK. Do not touch, move, spray, or clean your light fixture when it is plugged in. Allow it to cool down before handling. Recommended mounting clearance for your fixture is 8"-12" on all sides. Do not mount directly to any surface. Make sure to disconnect the power when changing the lamp.

## INITIAL SETUP

These systems based on the 50 Series ballasts are hard-wired, all-in-one systems. Therefore the primary initial setup task is to create secure hanging for the system using its integrated hangers and your chosen method of safe fixture suspension.

## LAMP INSTALLATION

1. Open both lamp holders by sliding them outwards and away from the center of the fixture, as shown in PHOTO A.

**⚠ Do not apply excessive force when installing lamp.**

**NOTE:** The bulb must be oriented so that the high voltage wire end/lead (the end near the getter, which is the small square tab attached to the wire loop) is installed in the socket end closest to the ballast as seen in **DIAGRAM A**.

2. Also be sure that the bulb is oriented so that the burner filament (the long wire that runs along the full length of the arc tube) is positioned upward, facing the top inside surface of the reflector.
3. Ensure that the wire ends/leads are not bent or frayed, as this will prevent proper installation. Begin by installing the double-ended lamp within the lamp holders shown in PHOTOS A, B & C.
4. The wire ends/leads must be fully seated as shown (PHOTOS D & E) before sliding each socket end closed.
5. After sliding the socket ends closed, be certain that there is no gap between the edge of the sliding section and the part it meets at the end of the slide path. Once lamp is positioned correctly, slide the lamp holder inward toward the center of the bulb to secure and lock the lamp in place as shown in PHOTOS F & G.

**PLEASE NOTE:** Do not force the lamp holders closed. This could cause damage to both the lamp and lamp holders. Do not handle lamp with bare hands. Always wear surgical or cloth gloves whenever possible when handling lamp to minimize fingerprints and oils left on the lamp. If the lamp needs cleaning after installation, use a soft dry cotton cloth to wipe off fingerprints/skin oils.



PHOTO A



PHOTO B

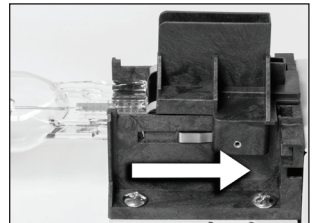

PHOTO C

## DIAGRAM A

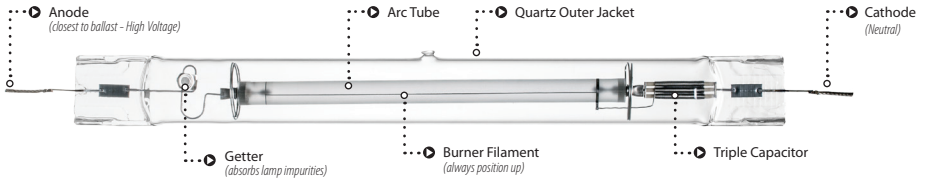

PHOTO D

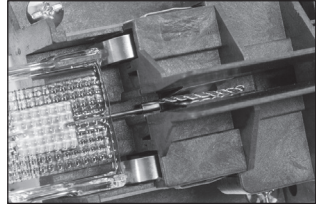

PHOTO E

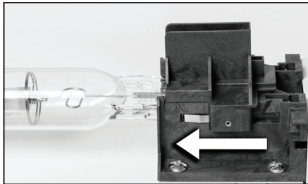

PHOTO F

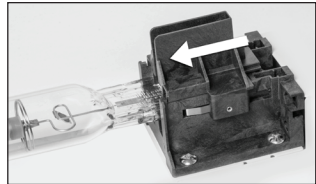

PHOTO G

## HANGING THE FIXTURE

1. Make sure your unit is unplugged.
2. Hang the fixture from a strong cord, chain or our rope ratchet hangers. Using the desired clip, one attaches to the integrated hanger located on the ballast (rear) and the other from the integrated hanger on the reflector (front). Make sure you have hooks solidly screwed into the studs in the ceiling. If you cannot locate the studs, insert expansion anchors into the ceiling. The hooks should be rated to hold at least 50 lbs each.



The Phantom Ballast Commercial DE is an ideal ballast choice for efficient growing. It was created with state-of-the-art microprocessor technology to utilize the industry's double-ended 1000W and 750W HPS lamps.

This ballast (and all 40/50 Series Phantom Ballasts) includes a Control Port on the front panel which allows connection to and data communication with the Autopilot PX1 Lighting Controller via USB. Use with the PX1 is optional—the 40/50 Series ballasts operate perfectly with standard manual control when not connected to a PX1.

### **WARNINGS**

- This ballast and the Control Port are compatible only with the Autopilot PX1 Lighting Controller. Do not connect any other device to the Control Port. Any attempt to connect it to an unrelated device or control it with an incompatible controller may result in damage to the ballast and will void the warranty.
- Use this ballast in greenhouses or indoor applications only. Position it in an area away from excessive heat or contact with liquids.
- This ballast does not rely on the luminaire enclosure for protection against accidental contact with live parts.
- Disconnect the ballast from the power supply before performing any maintenance, lamp changes, or other modifications.
- Contact the retailer or distributor for service if the ballast does not work after confirming the power connection, output connection, and bulb operation.
- Opening the ballast will void the warranty.
- This product may cause interference to radio equipment and should not be installed near maritime safety communications equipment or other critical navigation or communication equipment operating between 0.45-30 MHz.

### **INSTALLATION AND CONNECTION**

For proper lamp break-in, we recommend that you run the ballast and bulb at 100% power for at least 12 straight hours after initial startup. This will improve lamp life and performance.

1. Find a suitable location for the ballast with sufficient cooling and away from any heat source.
2. Install the lamp firmly into the lamp socket of the reflector- see LAMP INSTALLATION.
3. Remove the power cord from the box. Plug the power cord into the ballast.
4. Plug the power cord into the power source (electrical outlet).
5. Once the lamp has fired, set your desired wattage output level. Please note that the ballast decreases or increases output gradually to protect the lamp, so you might not see an instant increase upon changing your output percentage.

## NOTES ON VARIABLE OUTPUT CONTROL

- When a USB cable is connected to the ballast's control port, manual selection of wattage output is defeated. The power-level LEDs surrounding the variable output button on the bottom panel will go dark, and the LED labeled "PX1" will go on. When/if the USB cable is disconnected from the control port, output control is returned to the variable output button after a short delay, indicated by the LEDs becoming active again after start-up.
- Press the variable output button to cycle through the wattage levels. The appropriate LED indicator will light up to indicate selected wattage level (varies for 750W and 1000W models).
- This ballast has built-in hot-restrike programming to protect the lamp and ballast in the event of the ballast turning off unexpectedly. The ballast will not attempt to restart a hot lamp for at least 15 minutes. If your lamp fails to start immediately, **DO NOT cycle the power on and off**. This can damage the lamp and ballast. If after 30 minutes your lamp is still not lit, shut off power to the ballast, and reconnect. This will begin the startup sequence again.

## DEFINITION OF TERMS

**Main Voltage** – Rated input voltage range for the ballast.

**Operating Voltage Range** – The acceptable operating range for input voltage to the ballast. Deviations from the rated numbers may result in decreased ballast performance and additional case generated heat.

**Max Input Power** – Maximum possible wattage draw of the ballast.

**Amperage** – Input current or draw.

**Power Factor** – A measurement of how effectively the ballast converts electrical current to useful power output, in this case, output to the lamp. Power factor is measured between 0-1; the closer you get to 1, the more effective the circuit is said to be. The ballast's power factor is greater than .99.

**Ignitor Voltage** – Ballast output during ignition sequence.

**THD (Total Harmonic Distortion)** – A measurement of all harmonics present in a circuit. The higher the number, the more stress is applied to internal parts, the lamp, and the power grid. Generally, a number below 10% is considered desirable in an electronic ballast application.

**CF (Crest Factor)** – A measurement of how "clean" the ballast power output wave is. A perfectly clean output sine wave would have a CF of 1.414. Given that some harmonics must exist in an electrical system, the crest factor must always be higher than 1.414. Therefore, the closer the ballast is to a CF of 1.414, the easier it is on the lamp.

**ta (Ambient Temperature)** – Maximum rated ambient temperature for the ballast area. Excessive ambient temperature can result in ballast failure, safety shutdown, or lamp failure.

**tc (Case Temperature)** – Maximum temperature that the case of the ballast should reach. If the case temperature exceeds this number, the ballast may be malfunctioning or the ambient temperature may exceed the rating.

## ELECTRICAL SPECIFICATIONS

### PHANTOM 50 SERIES BALLAST ELECTRICAL SPECIFICATIONS

Model	Watts	Main Voltage	Operating Voltage Range	Max Input Power	Output Power Settings	Power Factor	Ignitor Voltage	THD	CF	ta	tc
PHB5010	1000W	120/240V	110-265V	1246W	600W-750W-825W-1000W-1150W	> 0.98	3-5 kV	< 8%	1.414-1.6	40°C/104°F	70°C/158°F
PHB5015	1000W	208/240V	185-265V	1236W	600W-750W-825W-1000W-1150W	> 0.98	3-5 kV	< 8%	1.414-1.6	40°C/104°F	70°C/158°F
PHB5020	1000W	277V	255-300V	1236W	600W-750W-825W-1000W-1150W	> 0.98	3-5 kV	< 8%	1.414-1.6	40°C/104°F	70°C/158°F
PHB5030	1000W	480V	450-510V	1215W	600W-750W-825W-1000W-1150W	> 0.98	3-5 kV	< 8%	1.414-1.6	40°C/104°F	70°C/158°F
PHB5040	750W	120/240V	110-265V	902W	400W-500W-600W-750W-825W	> 0.98	3-5 kV	< 8%	1.414-1.6	40°C/104°F	70°C/158°F

### BALLAST INPUT AMPERAGE REFERENCE

Model						
PHB5010	<b>I<sub>max</sub> 120/240V</b>	<b>1150W 120/240V</b>	<b>1000W 120/240V</b>	<b>825W 120/240V</b>	<b>750W 120/240V</b>	<b>600W 120/240V</b>
	10.5A/5.3A	10.2A/5.1A	8.9A/4.5A	7.4A/3.7A	6.7A/3.3A	5.4A/2.7A
PHB5015	<b>I<sub>max</sub> 208/240V</b>	<b>1150W 208/240V</b>	<b>1000W 208/240V</b>	<b>825W 208/240V</b>	<b>750W 208/240V</b>	<b>600W 208/240V</b>
	6.0A/5.3A	5.8A/5.1A	5.1A/4.4A	4.2A/3.7A	3.9A/3.3A	3.1A/2.7A
PHB5020	<b>I<sub>max</sub> 277V</b>	<b>1150W 277V</b>	<b>1000W 277V</b>	<b>825W 277V</b>	<b>750W 277V</b>	<b>600W 277V</b>
	4.6A	4.4A	3.8A	3.2A	2.9A	2.3A
PHB5030	<b>I<sub>max</sub> 480V</b>	<b>1150W 480V</b>	<b>1000W 480V</b>	<b>825W 480V</b>	<b>750W 480V</b>	<b>600W 480V</b>
	2.6A	2.5A	2.2A	1.8A	1.6A	1.3A
PHB5040	<b>I<sub>max</sub> 120/240V</b>	<b>825W 120/240V</b>	<b>750W 120/240V</b>	<b>600W 120/240V</b>	<b>500W 120/240V</b>	<b>400W 120/240V</b>
	7.6A/3.8A	7.4A/3.7A	6.7A/3.3A	5.4A/2.7A	4.5A/2.2A	3.6A/1.8A

### BALLAST LED STATUS INDICATORS

STATUS	DIMMING BUTTON	SELECTED POWER LED
Warm Up	On	Slow Flash
Normal Operation	On	On
Stand By	Slow Flash	Slow Flash
Ballast Fault	Off	Off
Lamp Fault	Off	Rapid Flash
End of Life Lamp Indicator	Rapid Flash	Off
Connection Error	Flash X 1	Off
High Input Voltage	Flash X 2	On
Low Input Voltage	Flash X 3	On
Over Temperature	Flash X 4	On

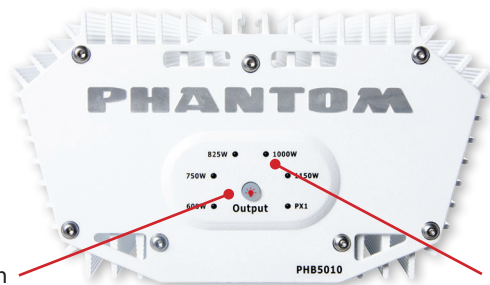

Variable Output Button

Selected Power LEDs

## RECOMMENDED WIRING DIAGRAMS

Each ballast **MUST** be wired to the main's neutral line back to the circuit.  
**DO NOT** "daisy-chain" a neutral line with any other ballast.

### RESIDENTIAL VOLTAGES - SINGLE PHASE POWER

**120/208V**  
 (Supply voltage 120V/208V)

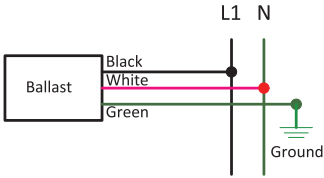

**240V**  
 (Supply voltage 120V x 2)

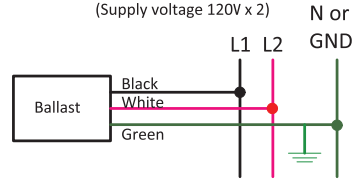

### COMMERCIAL VOLTAGES - THREE PHASE POWER

**208V**  
 (Supply voltage 208V)



**480V**

(Supply voltage 480V)  
 Electronic ballasts

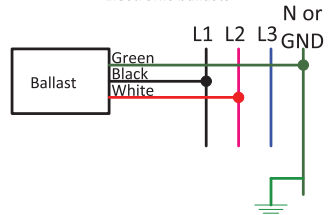

**277V/347V**  
 (Supply voltage 480V/600V)

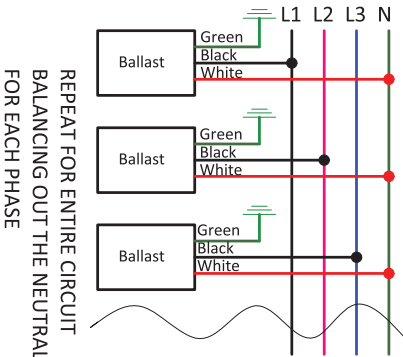

**480V**

(Supply voltage 480V)  
 Magnetic ballasts

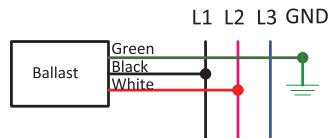

### 1. Environmental Controllers

- When setting restrike delays with your environmental controller, it is best to set a restrike delay at 20 minutes or longer to prevent constant restrikes throughout the day.
- When installing your controller, it is best to program the controller for a staggered start with 40 luminaires or less on each start.
- It is best to use special HID relays and high inrush circuit breakers to ensure proper performance.
- Lighting sub-panels should have a fan installed to prevent high heat of the sub-panel and optimum performance.

### 2. Autopilot PX1 Controller

The Autopilot PX1 controller is designed to work with the Phantom Commercial DE Electronic Ballast. Follow the PX1 Controller instructions for proper operation and to avoid ballast damage. Typical setup for the PX1 Digital Lighting Controller is shown below.

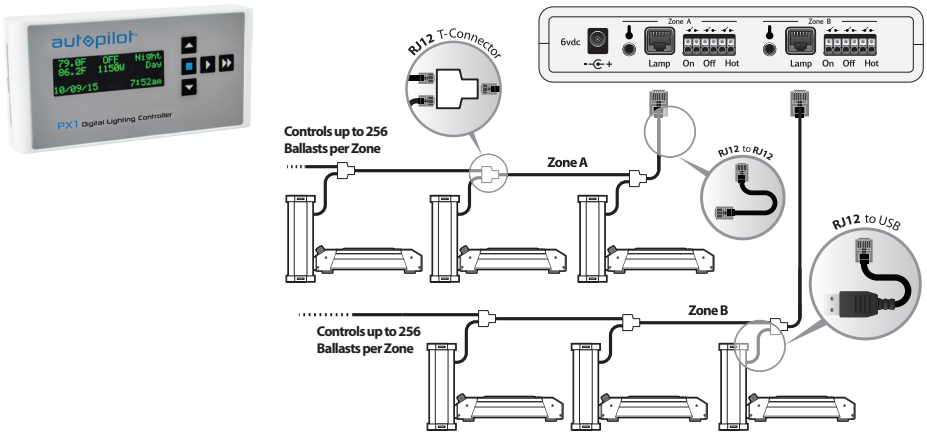

### PROPER OPERATING ENVIRONMENT

- Always provide a well-ventilated environment where ambient temperatures do not exceed 40°C (104°F) regardless of whether the ballasts are in operation or off. Excessive temperatures can inhibit performance and may cause damage or shorten the life of the ballasts and void the warranty.
- Do not run or store lights in the greenhouse unless proper environmental cooling systems are in operation. Greenhouses that are “shut down” can record excessively high temperatures resulting in premature equipment failure.
- When calculating cooling needs for your greenhouse, take into consideration the excessive heat that can be shed by HID lighting.
- This ballast is intended for indoor or greenhouse use only. Do not run lights where water will come in direct contact with the ballast or lamp.



### Replacing Lamps

It is recommended to replace a nonworking lamp immediately. Failure to do so could damage the ballast or components over time.

Never remove a lamp when a ballast is receiving power. Never have a powered ballast without a lamp inserted in the socket. This can be both dangerous and harmful to the ballast. Electronic ballasts may shut off if this occurs.

### Lamp Replacement Steps

- Disconnect power to the ballast.
- Make sure that the lamp is cool to prevent burns.
- Remove and replace the suspected bad lamp with a known working lamp.
- Make sure the lamp is securely installed into the lamp holders to ensure proper performance. Failure to properly install the lamp can reduce performance and can cause lamp and ballast failures.
- Power the ballast. The lamp should immediately start. If it does not, allow 3 minutes for the ballast to attempt to re-strike the lamp. Some lamps may require a burn-in period of 12 hours to ensure proper performance and consistent starting.
- If the lamp does not ignite, check the troubleshooting section or consult a PARsource/Hydrofarm representative.

### Tracking Performance

It is best to map out the lights by location to track any maintenance or replacement data. Consult PARsource/Hydrofarm for examples of product mapping.

### TIPS

- The lamp may require 10-30 minutes cooling time before restarting.
- After you plug the reflector in, the bulb may require several minutes to reach its full brightness. In the event of a momentary power interruption, the bulb will not restart immediately.
- Some variation in the color of light emitted by the bulb is not unusual, especially in the first 100 hours of operation.
- Never pull the cord to unplug the reflector, pull the plug only.
- Avoid scratching the bulb, subjecting it to undue pressure, or getting it wet when it is hot; these actions may cause the bulb to break.
- In the event of bulb breakage, immediately unplug the reflector to prevent exposure to ultraviolet energy, which may be harmful to eyes and skin.
- Keep room temperature below 95°F, with adequate air circulation by fan in the growing area.
- The DE lamp produces very high-intensity light and was originally designed for commercial growing operations. Please take care to consider proximity to plants when installing your fixture.

### General Information

Do NOT open the ballast's chamber without consulting a PARsource/Hydrofarm representative first. Should a failure occur, please contact your distributor or PARsource/Hydrofarm for a replacement or repair on any products with an active warranty.

### LED Indicators

This ballast comes with smart LED indicators on the ballast that can help you with diagnosis. The ballast must be powered for the indicators to work. See the chart on Page 11 for more details.

Electronic ballasts come with safety shut-offs. A non-working ballast may be in the shut-off mode. To reset the shut-off, turn off the power to the ballast for a minimum of 15 minutes. Restart the ballast. If the ballast does not start, review the basic diagnosis steps or consult with a PARSource/Hydrofarm representative.

### BASIC DIAGNOSIS STEPS

How to identify whether the issue is with the bulb or the ballast:

- Turn on the lights
- Identify which lights are not on (the locations should be mapped)
- Make sure there is power to the ballast (you can check this with a multimeter at the receptacle)
- Is the circuit live?
- Is the ballast plugged in or properly wired?
- Make sure ballast and reflector cords are securely connected
- Make sure lamps are securely installed into the lamp holders
- Cut power to the ballast
- Remove lamp and replace with a known working lamp
- Repower the ballast

If lamp ignites, then the original lamp is bad. If the lamp does not work, then replace the ballast.

**NOTE:** *When you repower the ballasts, they may not restrike immediately. Wait up to 15 minutes to make sure the lamps have had enough time to restrike.*

## COMMON SYMPTOMS (DE LAMPS)

Lamp flickering	Erratic starting	Slow Starting	Dim Lamp (Low Light)	Lamp not lighting	Possible Reason	How to Diagnose
●	●	●	●	●	Bad lamp	Place a known working lamp in the ballast. If it does not flicker or have erratic start, the original lamp is bad.
●					Lamp not installed properly	Check to see if lamp is properly and securely installed.
●	●	●			Lamp / ballast incompatibility	Try another lamp brand.
●	●			●	Inconsistent current	Electronic ballast: Is the line conditioned.
●	●				Lamp not "burned in"	"Burn in" (run the lamp for 24 hours).
●	●		●	●	Old lamp/excessive use of lamp	Check the rated hours: Has it been run 60% of the rated hours? If yes, try a new lamp.
			●		Possible wrong lamp type for ballast	Try another lamp type or confirm proper ballast for lamp type.
			●		Incorrect wattage for ballast	Confirm proper wattage for ballast and lamp.
			●	●	No power	Check circuit panel and power cord connections.
			●	●	Bad fuse/circuit	If on panel, replace. If on the ballast, replace.
				●	Bad ballast (failure)	Place lamp in known working ballast. If the lamp works, the ballast is bad.

## SYSTEM DIMENSIONS

### 1000W 208V/240V OPEN SYSTEM DIMENSIONS - PHDEOK11, PHDEOK13, PHDEOK15

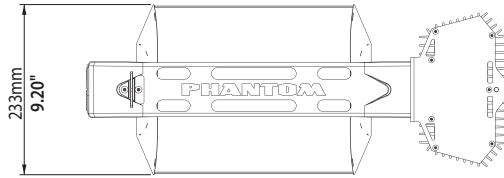

PHDEOK11  
OPEN SYSTEM 1000W 208V/240V

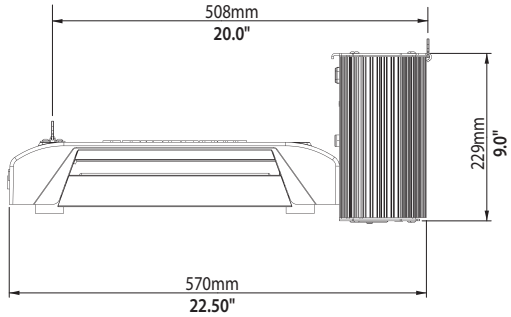
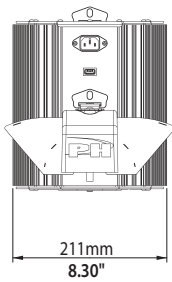

### 750W/1000W 120V/240V OPEN SYSTEM DIMENSIONS - PHDEOK12/PHDEOK72

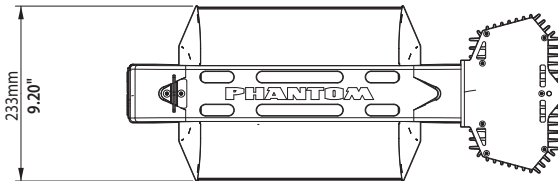

PHDEOK12  
OPEN SYSTEM 1000W 120V/208V/240V

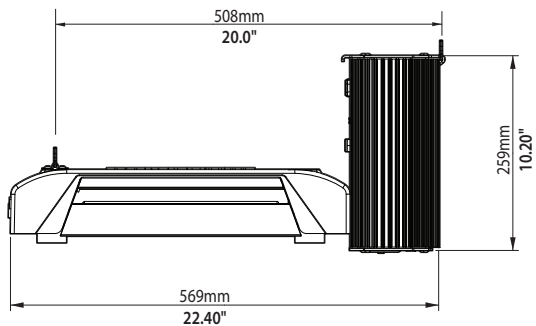
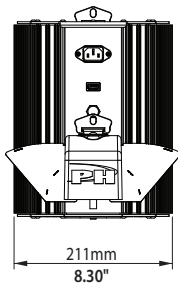

## SYSTEM DIMENSIONS

### 1000W 208V/240V OPEN SYSTEM DIMENSIONS - PHDESK11, PHDESK13, PHDESK15

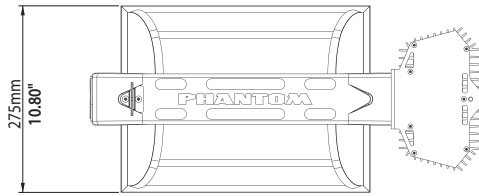

PHDESK11

ENCLOSED SYSTEM 1000W 208V/240V

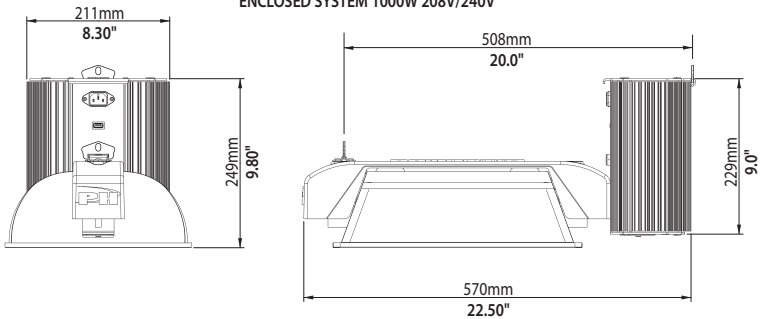

### 750W/1000W 120V/240V ENCLOSED SYSTEM DIMENSIONS - PHDESK12/PHDESK72

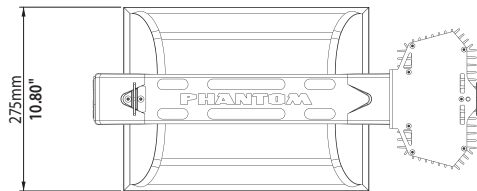

PHDESK12

ENCLOSED SYSTEM 1000W 120V/208V/240V

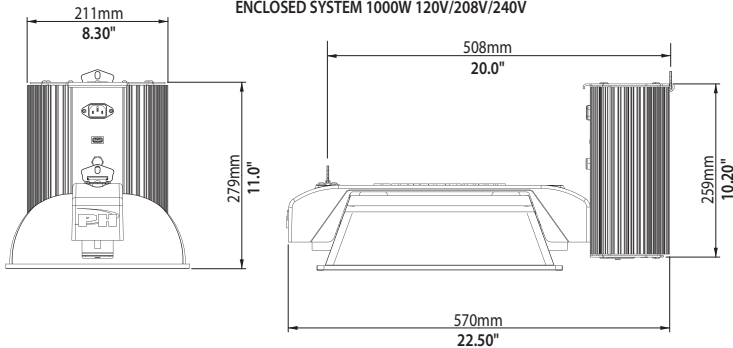

## SYSTEM DIMENSIONS

### 1000W 208V/240V SUPER DEEP SYSTEM DIMENSIONS - PHDEDK11

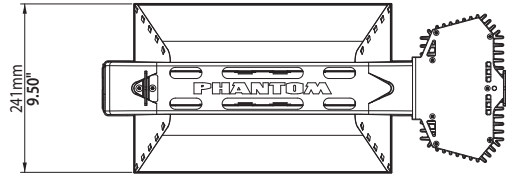

PHDEDK11

SUPER DEEP SYSTEM 1000W 208V/240V

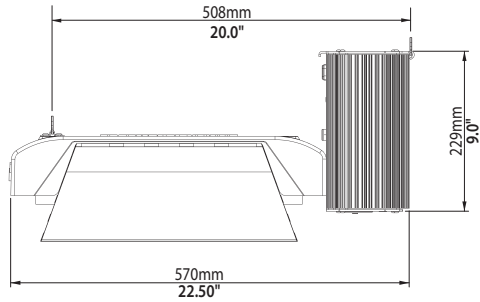
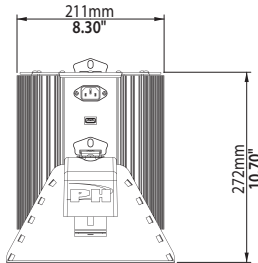

### 750W/1000W 120V/240V SUPER DEEP SYSTEM DIMENSIONS - PHDEDK12/PHDEDK72

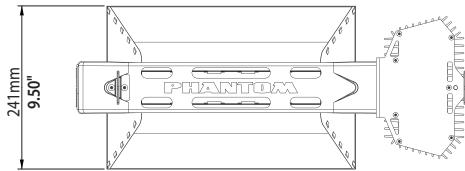

PHDEDK12

SUPER DEEP SYSTEM 1000W 120V/208V/240V

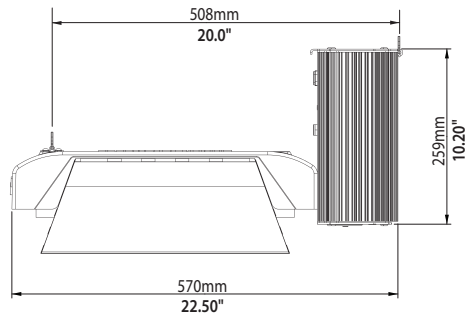
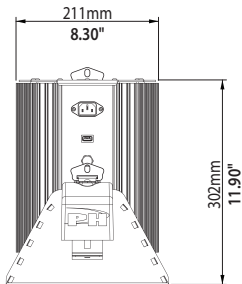

# POLAR DIAGRAMS

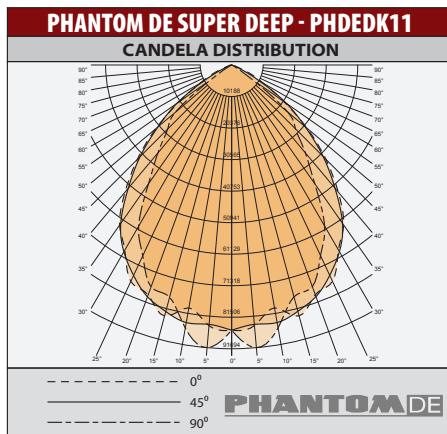
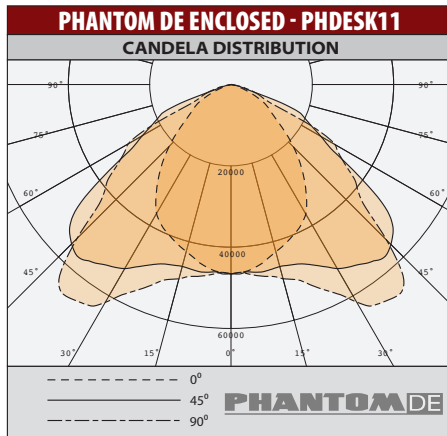
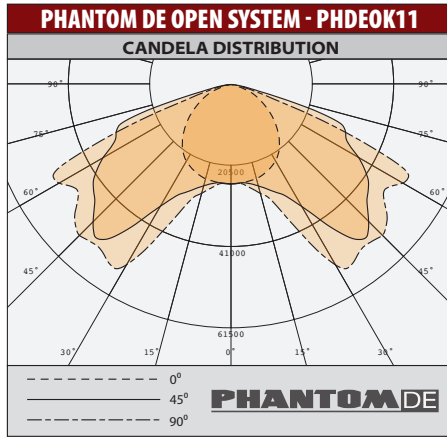

# WARRANTY



## LIMITED WARRANTY

Hydrofarm warrants the **Phantom Double-Ended Lighting System** to be free from defects in materials and workmanship. The warranty term is for 3 years beginning on the date of purchase. Misuse, abuse, or failure to follow instructions is not covered under this warranty. Hydrofarm's warranty liability extends only to the replacement cost of the product. Hydrofarm will not be liable for any consequential, indirect, or incidental damages of any kind, including lost revenues, lost profits, or other losses in connection with the product. Some states do not allow limitation on how long an implied warranty lasts or the exclusion of incidental or consequential damages, so the above limitations or exclusions may not apply to you. Hydrofarm will, at our discretion, repair or replace the **Phantom Double-Ended Lighting System** covered under this warranty if it is returned to the original place of purchase. To request warranty service, please return the **Phantom Double-Ended Lighting System**, with original sales receipt and original packaging, to your place of purchase. The purchase date is based on your original sales receipt.



Get Connected with the Hydrofarm Community:



Like us on Facebook, follow us on Twitter,  
and check out *Hydrofarmtv* on YouTube and Instagram!

PHANTOM DOUBLE-ENDED LIGHTING SYSTEMS Instructions revised - February 24, 2017 2:26 PM



[Hydrofarm.com](http://Hydrofarm.com)