

Carbon-X System / CDA-1

Carbon-X Multiple Zones CO2 Alarm System

The CDA-1 / Carbon-X System is designed to protect customers and workers near commercial indoor growing areas that use supplemental CO2, satisfying all local and state regulations. It provides critical monitoring of CO2 levels in up to 13 separate zones.



CDA-1 for CO2 Alarm System

The Carbon-X System offers both high and low level alerts. The sensors will constantly monitor the CO2 level of the areas. If an unsafe level of CO2 is detected, the system can shut down CO2 flow, vent the area, turn on visible and audible alarms and even send signals to a fire alarm panel and an emergency call to the fire department by interfacing to the fire / alarm panel in the facility. The Carbon-X System can also control various devices such as ventilation fans, dampers, and main CO2 valves.

The system can control up to 40 outputs in total. Each output can be linked to an individual sensor or all sensors for customized programming. The TrolMaster app can be used to remotely monitor the Carbon-X and to receive user-alerts / notifications in case of high CO2 levels being detected.

Specifications

CARBON-X (CDA-1)

Product Capacity

Sensors	Maximum 13/pcs
Devices	Maximum 40/pcs

Operating Requirements

Temperature	32 °F-122 °F
Humidity	5% to 90% RH

Power Supply

Supply Voltage	100-240VAC, 50/60Hz
-----------------------	------------------------

Dimensions & G.W.

Dimensions	275*164*62mm 0.5A
Approx. G.W.	1.08kg

Display & Control

Size	Backlit 128x128 LCD Display
Control	Button Control
Language	English (International)
Micro-SD	Save/Copy/Import/ Export data

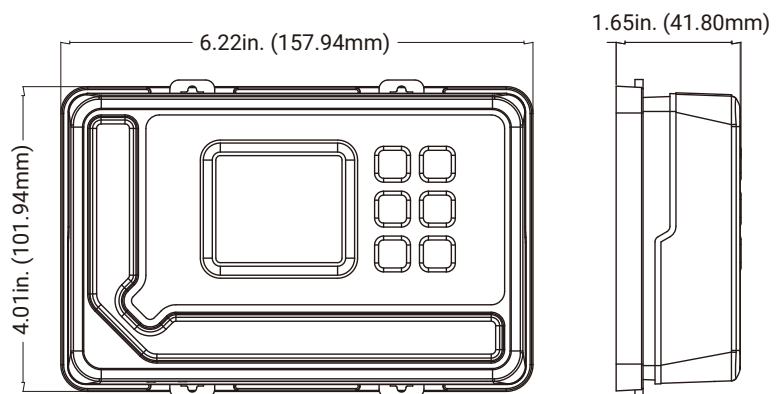

Connection

Splitter Hub Connection



The sensors and control modules (device stations) are connected to the CDA-1 with a standard RJ12 cable and SPH-1 splitter hub, making installation as simple as plug-and-play.

CO2 Monitoring

CO2 Sensor

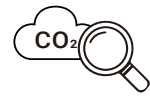

The CO2 sensor (MBS-K30) can be connected to the Carbon-X system and constantly monitor the CO2 level of different zones. (up to 13 separate zones.)

Audible and Visible Alarm

With Carbon-X System



The CO2 Alarm Stations are audible/visible alarms to be mounted inside or outside the room to monitor, and sound an alarm (both visible and audible) in the event of the CO2 level going above normal or safe levels. It can be linked to either the low or the high level CO2 sensors, or it can be linked to both sensors for complete redundancy.



Audible Alarm

The AS-1 CO2 Alarm Station is designed to sound an alarm (both visible and audible) in the event of the CO2 level going above normal or safe levels.

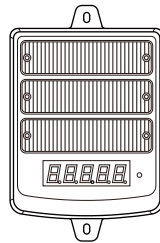

Visible Alarm

The AS-2/3/4 has an LED display indicator and an LCD display showing the digital ppm level reading. There are multiple colors available for different fire regulation requirements.

Emergency Control

Device Station



When a high CO2 level is detected, and it exceeds the standard level, the Carbon-X can automatically take the measures below at the same time.

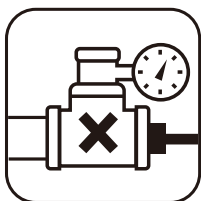

Shut Off Main CO2

The CO2 Emergency Stop Station (DSE-1) or Low Volt station (DSV-1) will shut off the solenoid valve of the CO2 tank automatically

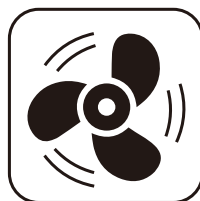

Turn On Ventilation Fan

The CO2 device station (DSC-1) will turn on the ventilation fan to remove the CO2 (up to 13 separate zones)



Emergency Alert

The Dry Contact station (DSD-1) can integrate with the emergency fire alarm system to the local fire department

Monitor On App



Mobile App

The LCD interface and buttons on the CDA-1 can be used to change settings and view data, PLUS the CDA-1 can be monitored with TrolMaster's free smartphone App which offers remote monitoring, remote settings and receiving push alert notifications anytime, anywhere. The Carbon-X system also provides internet connectivity to a cloud service that will send push alerts to the APP.



Steps To Connect To The App

To connect the CDA-1 to your App, first connect it to the Internet. Use a CAT 5/6 cable to connect the CDA-1 to your router directly for the most reliable connection. When the controller is connected to the internet, the internet symbol will be displayed on the lower right corner of the LCD display. To link the CDA-1 to the App, simply open the TM app and scan the QR code on the front LCD screen of the controller. (Go to System – QR Code.)

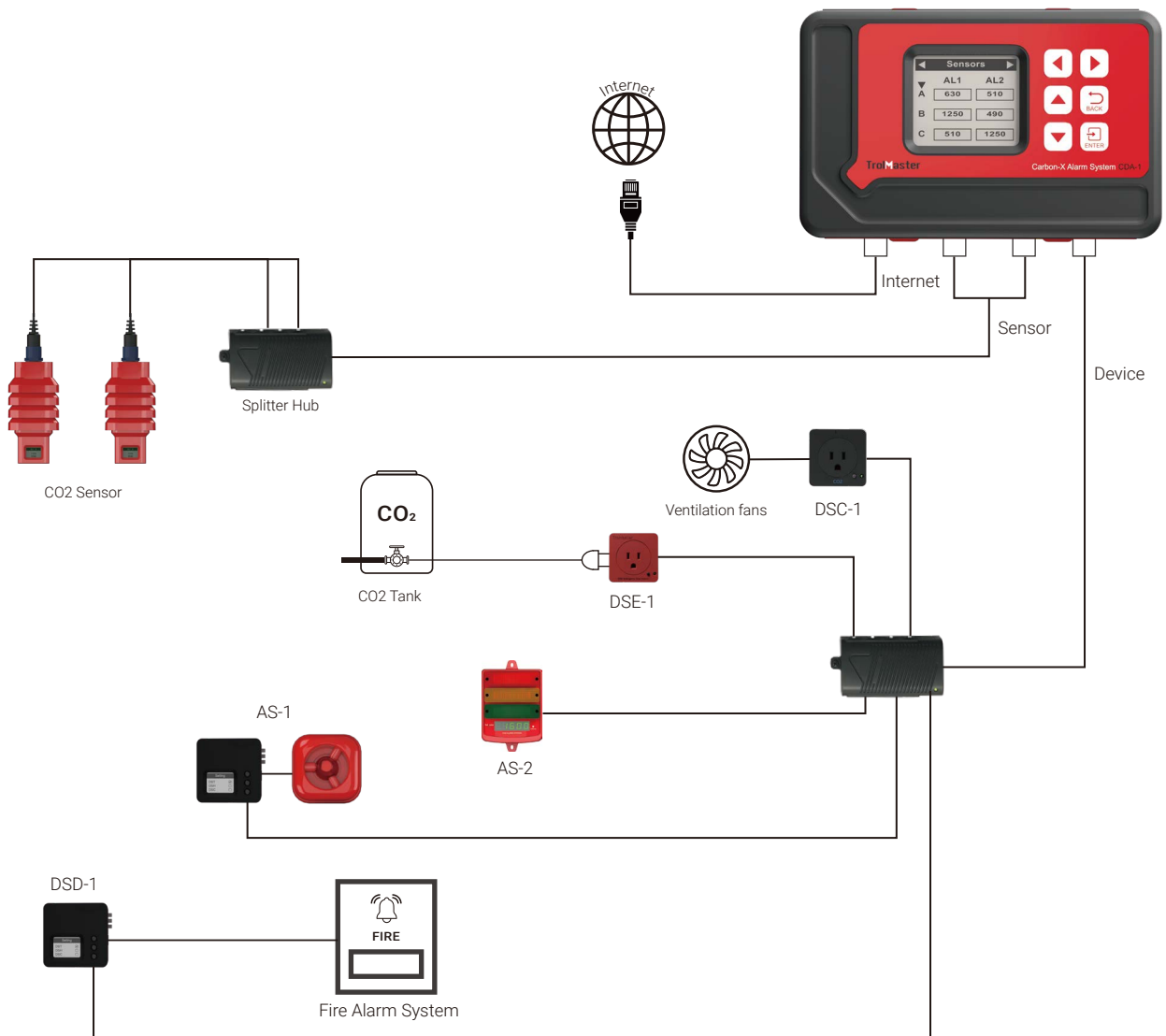

TrolMaster

Carbon-X

CO2 Alarm System

-  Auto Shut-Off Of CO2 Solenoid Valve
-  Auto Control Of Exhaust Fan To Remove CO2
-  Integration With Fire Alarm System
-  Modular Designed
-  Monitors Up To 13 Zones
-  2 CO2 Alarm Levels: 5000 ppm and 30,000 ppm

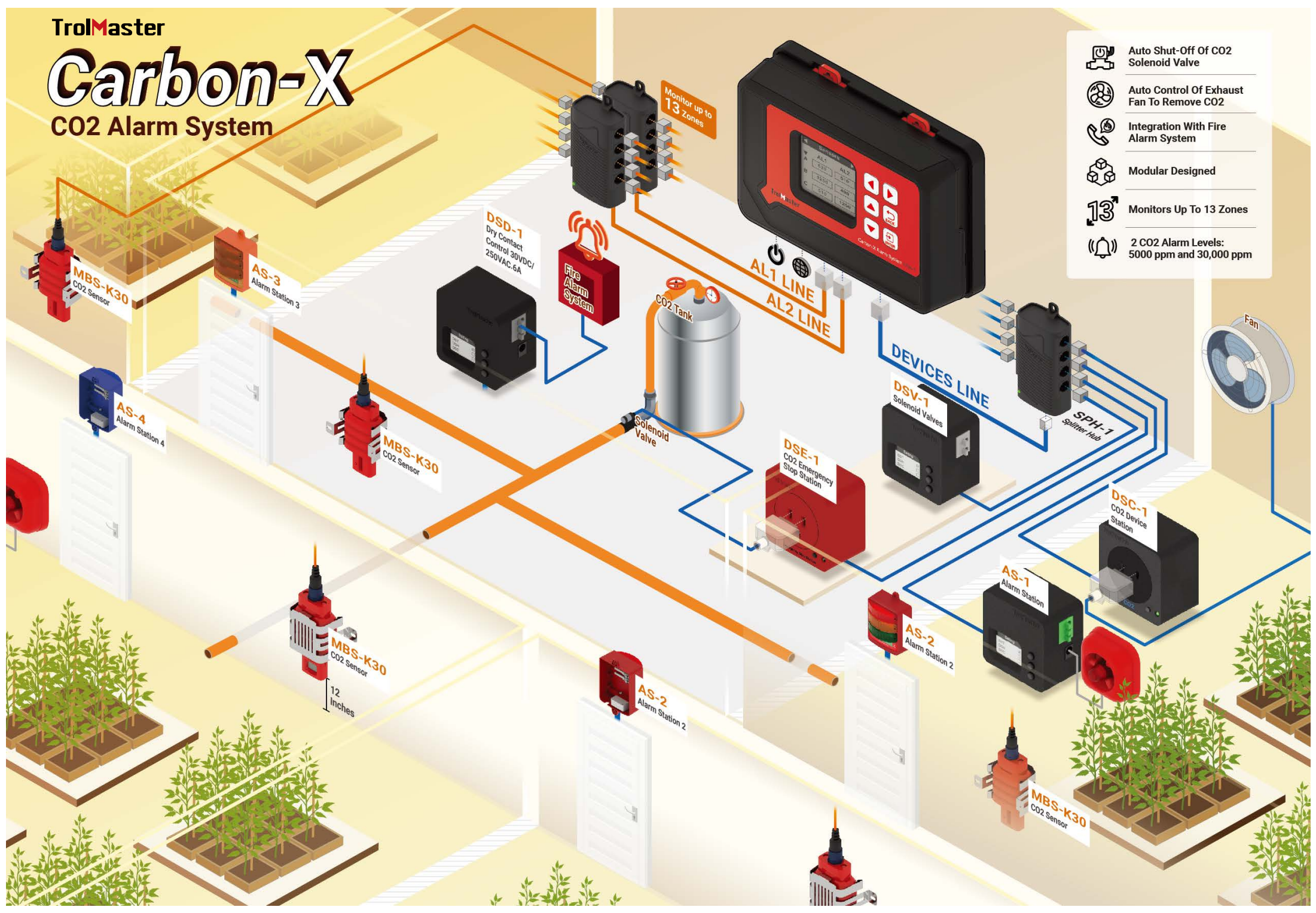

Monitor up to 13 Zones

DSD-1
Dry Contact
Control 30VDC/
250VAC.6A

Fire
Alarm
System

AL1 LINE
AL2 LINE

DEVICES LINE

SPH-1
Splitter Hub

DSV-1
Solenoid Valves

DSE-1
CO2 Emergency
Stop Station

DSC-1
CO2 Device
Station

AS-1
Alarm Station

AS-2
Alarm Station 2

AS-2
Alarm Station 2

MBS-K30
CO2 Sensor
12
Inches

AS-3
Alarm Station 3

AS-4
Alarm Station 4

MBS-K30
CO2 Sensor

MBS-K30
CO2 Sensor

MBS-K30
CO2 Sensor

