

GARDENING | IRRIGATION
POND | FOUNTAIN



ECO+ PLUS™

ELITE SERIES

COMMERCIAL GRADE

AUTOMATIC SUBMERSIBLE PUMP

INSTRUCTIONS FOR INSTALLATION AND MAINTENANCE

727184 | 1746 GPH

727186 | 3168 GPH



INDEX

1. APPLICATION	2
2. PUMPABLE LIQUIDS	3
3. TECHNICAL SPECIFICATIONS	3
4. FITTINGS AND DIMENSIONS	4
5. PERFORMANCE CURVE AND FLOW RATES	5
6. MANAGEMENT AND INSTALLATION	6
7. START-UP	7
8. PRECAUTIONS	7
9. MAINTENANCE AND CLEANING	8
10. TROUBLESHOOTING	9
11. LIMITED WARRANTY	10
12. PLANNING AND NOTES	11-12



WARNING: *Read entire instruction manual carefully before using.*



REMOVE THE POWER PLUG FROM THE ELECTRICAL SOCKET BEFORE HANDLING THE PUMP TO AVOID ELECTRIC SHOCK.



The pump must always be activated when it is immersed in water. If all of the water is evacuated, the pump must be deactivated immediately by removing the plug from the electrical socket. **ABSOLUTELY AVOID DRY OPERATION.**



Do not use in swimming pools, ponds or basins where people are present.
Do not use for pumping hydrocarbons (petrol, diesel fuel, combustible oils, solvents).
Do not pump continuously for long periods of time unless in the case of emergency.



Always clean the pumps before storage. See the chapter "Maintenance and Cleaning".

- 1. PUMPABLE LIQUIDS** - Max. particle size Ø.20 inch.
The pump is watertight and must be immersed in liquid.

Fresh water	●
Rainwater	●
Clear waste water	●
Dirty water	○
Waste water containing solid particles with long fibers	○
Fountain water	●
River or lake water	●

● Suitable
○ Not suitable

2. TECHNICAL SPECIFICATIONS

- Supply voltage: 115 – 120V, see electrical data plate
- Delayed line fuses (115 – 120V version): indicative values (Ampere)
- Storage temperature: 14° F – 104° F

	TECHNICAL SPECIFICATIONS	Product# 727184 1746 GPH 1/5 HP	Product# 727186 3168 GPH 1/4 HP
Electrical data	Power	275 Watt	650 Watt
	Voltage	115 V-120 V AC	115 V-120 V AC
	Frequency	60 Hz	60 Hz
	Amps	2.6	6
Hydraulic data	Flow rate max.	29.1 gpm 6600 l/h	52.8 gpm 12000 l/h
	Max. pressure	8.7 psi 0.6 Bar	13.2 psi 0.9 Bar
	Max. head	19.7 ft 6 m	29.5 ft 9 m
	Max. working pressure	87 psi 6 Bar	87 psi 6 Bar
	Low suction capability (AUTO)	1.78 in 45 mm	1.78 in 45 mm
	Low suction capability (MAN)	0.08-0.12 in 2-3 mm	0.08-0.12 in 2-3 mm
	Max. particle size	0.2 in 5 mm	0.2 in 5 mm
Dimensions/weight Range of use/materials	Pump dimensions <i>See illustration</i>	8.7 in x 7.3 in x 13 in 221 mm x 185 mm x 330 mm	8.7 in x 7.3 in x 13 in 221 mm x 185 mm x 330 mm
	Length of power cable	32.8 ft 10 m	32.8 ft 10 m
	Net weight	10.6 lbs 4.98 kg	10.6 lbs 4.98 kg
	Liquid range temperature	32°-95° F 0°-35° C	32°-95° F 0°-35° C
	Max. ambient temperature	104° F 40° C	104° F 40° C
	DNA / DNM NPT	1 1/4 in M / 1 1/4 in M	1 1/4 in M / 1 1/4 in M
	Impellers	1	1

FITTINGS AND DIMENSIONS

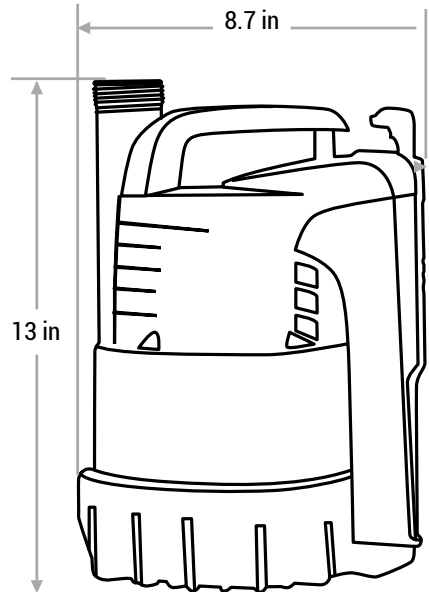
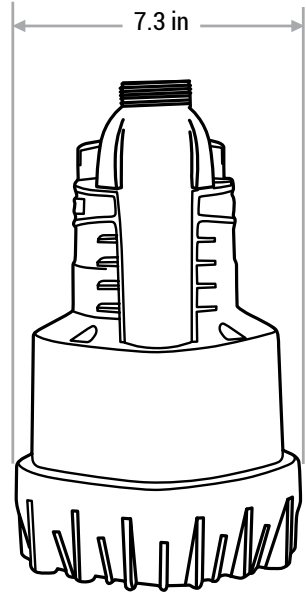

PERFORMANCE CURVE

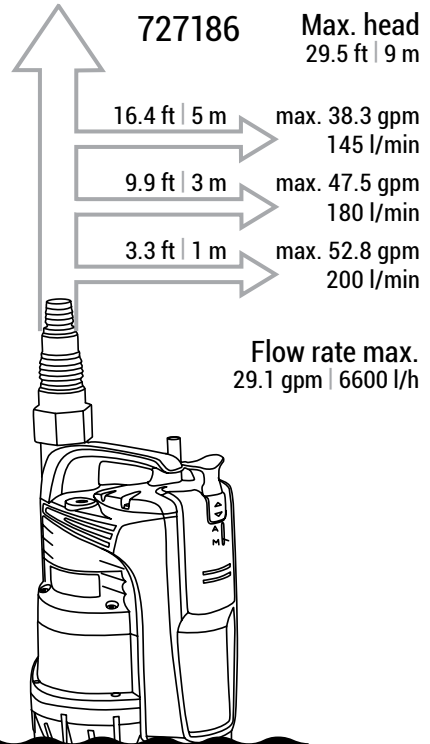
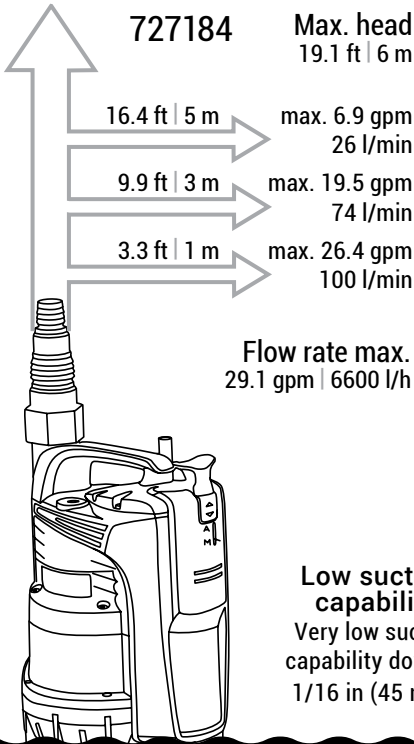
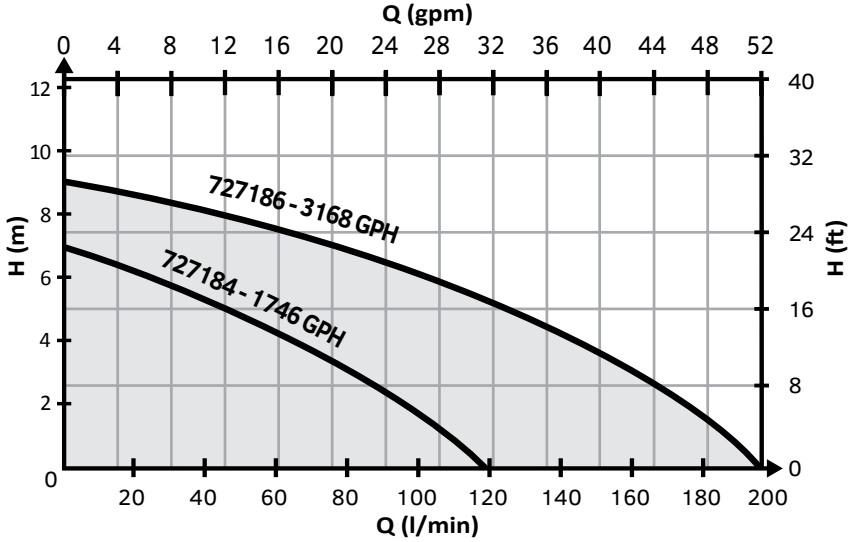

Low suction capability
Very low suction capability down to 1/16 in (45 mm).

 **THE PUMP MUST BE SUPPORTED BY A BASE. NEVER SUSPEND THE PUMP FROM PIPES.**

3. MANAGEMENT

- 3.1 Storage:** Pump must be stored in a dry, dust free covered area that is free from vibrations. Keep the pump in its original packaging until time of installation.
- 3.2 Transport:** Avoid subjecting the pump to needless impacts and collisions.

4. WARNINGS

-  Do not carry pump by the power cable. Always carry pump using the handle.
- Never allow the pump to run dry.
 - The sealing device contains a non-toxic lubricant which may alter the characteristics of pure water in the unlikely event of leaks.

5. INSTALLATION

The electrical system must be compliant with local codes.

- Screw on the elbow with hose-tail fitting provided. Use a pipe tightening clamp to secure the pipe to the fitting.
- If the bottom of the trap where the pump is to be placed is particularly dirty, a raised support should be provided so as to avoid blocking of the suction grid (Fig.1)
 - Totally immerse the pump in the water.
 - Ensure that the minimum dimensions of the trap in which it is housed are as follows:
Min. base dimensions 7.87"x7.87" (200x200 mm)
Min. height 15.75" (400 mm)
 - The dimensions of the trap must always be in relation to the quantity of water arriving and to the flow of the pump, so as not to subject the motor to excessive starts/hour. It is strongly recommended not to exceed 20 starts/hour.

(Fig.1)

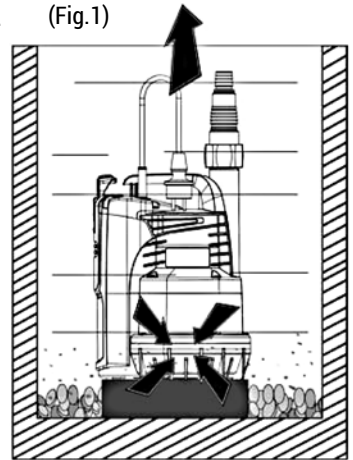

 **ALWAYS INSTALL THE PUMP IN VERTICAL POSITION.**

6. ELECTRICAL CONNECTION

-  The length of the power cable limits the maximum depth of pump immersion. Follow the indications on the technical data plate and technical specifications on page 3.

7. START-UP

- 1) Insert the plug of the power cable in a 115 – 120V power socket.
- 2) When the float reaches the ON level, the pump will start and will continue operating until it reaches the OFF level.

Automatic operation (A):

- 3) The integrated float switch starts and stops the pump automatically when the indicator (2) is positioned on "A".

Manual operation (M):

- 4) To start the pump, lift the knob (3) position indicator (2) on "M". In these conditions the suction level of the pump will be down to 0.08"-0.12" (2-3 mm).
- 5) In order to check the performance and/or clean the float switch, open the cover (1) position the knob (3) to "O".

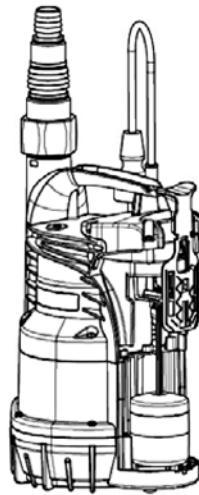
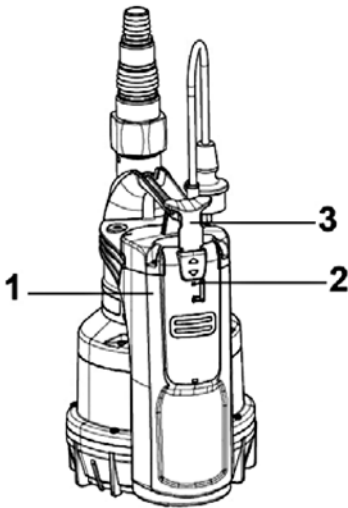

Automatic operation (A)

Manual operation (M)

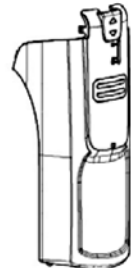

8. PRECAUTIONS

RISK OF FREEZING: when the pump remains inactive at a temperature lower than 32° F, it is necessary to ensure that there is no water residue which could freeze causing cracks in the plastic parts. If the pump has been used with substances that tend to form deposits, or with water containing chlorine, rinse after use with a powerful water jet in order to avoid the formation of deposits or coatings which would reduce the performance of the pump.

9. MAINTENANCE AND CLEANING

In normal operation the pump does not require any type of maintenance. In any case, all repair and maintenance work must be carried out only after having disconnected the pump from the power supply. When restarting the pump, ensure that the suction filter is always fitted so as not to create the risk or possibility of accidental contact with moving parts.

9.1 Cleaning the suction grid

(Fig. 2)

- Switch off electric power to the pump (a).
- Drain the pump.
- Unscrew the screws on the filter (b).
- Remove the suction grid (c).
- Clean and reassemble the suction grid.

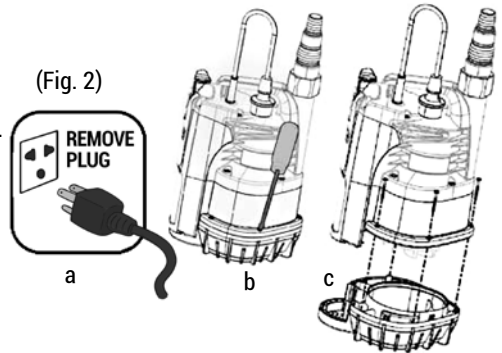

9.2 Cleaning the impeller

(Fig. 3)

- Switch off electric power to the pump (a).
- Drain the pump.
- Unscrew the screws on the filter (b).
- Remove the suction grid (c).
- Wash the pump with clean water to remove possible impurities between the motor and the pump jacket (d).
- Clean the impeller (d).
- Check that the impeller can turn freely.
- Reassemble parts in inverse order of disassembly.

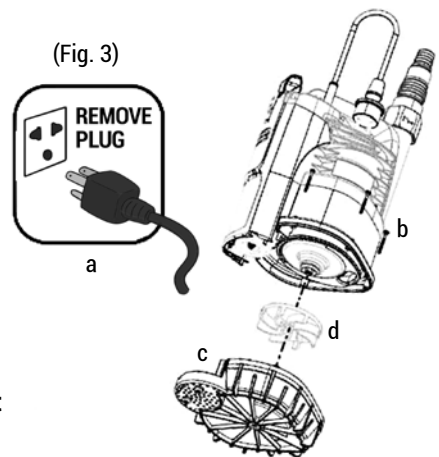

9.3 Cleaning and testing of integrated float

(Fig. 4)

- Switch off electric power to the pump (a).
- Drain the pump.
- Push the switch lever and disassemble the cover of the float (b).
- Remove the float, check if anything prevents free flow and proceed with cleaning (c).
- Reassemble parts in inverse order of disassembly.

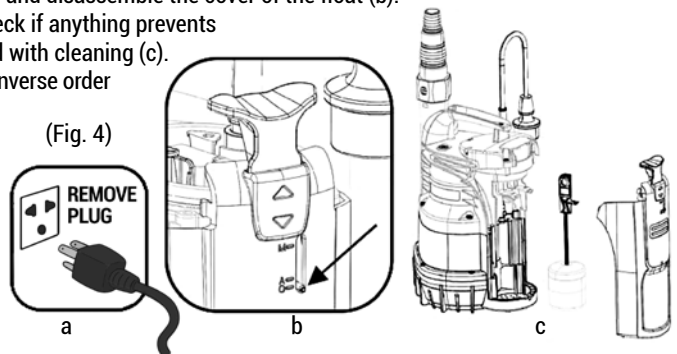

10. TROUBLESHOOTING



DISCONNECT THE PUMP FROM THE POWER SUPPLY BEFORE TROUBLESHOOTING.

If there is any damage to the power cable or pump, necessary repairs or replacements must be performed by the manufacturer, authorized dealer, or by an equally-qualified party in order to prevent any risks.

ISSUE	POSSIBLE CAUSES	REMEDIES
The motor does not start or make any noise.	A. Check if voltage is reaching motor. B. Check the protection fuses. C. Switch is not activated by the float.	A. Check if plug is inserted correctly. B. If burnt out, change them. C. Increase the depth of the trap.
The pump does not deliver flow.	A. Suction grid or hose are blocked. B. The impeller is worn or blocked. C. The head required is higher than the pump's performance. D. Presence of air. E. Water level is lower than the suction minimum.	A. Remove the obstructions or straighten the hose if it is twisted. B. Replace the impeller or remove the obstruction. C. Replace pump with a pump with a higher head. D. Wait at least 1 minute until it is eliminated.
The pump does not stop.	A. The float is not deactivating the switch.	A. Check that the float to see if it moves freely.
The flow rate is insufficient.	A. Check suction grid for blockage. B. Check the impeller and the delivery pipe for blockage or encrusted. C. Ensure the check valve is not partially blocked.	A. Remove any obstructions. B. Accurately clean the check valve.
The pump stops after running for a short time.	A. The thermal overload protection device stops the pump.	A. Check that the fluid being pumped is not too dense. B. Check that the water temperature is not too high. C. Make sure there is no solid particles blocking the impeller. D. Make sure power supply complies with the technical specifications.

LIMITED WARRANTY

When purchased from an authorized Hawthorne dealer, this product is covered by a **LIMITED WARRANTY available at hawthornegc.com/warranties**. You can also obtain the Terms of Sale and Limited Warranty by calling Hawthorne toll free at 1-888-478-6544 or writing Hawthorne at: Hawthorne Hydroponics LLC, 3204 NW 38th Circle, Vancouver, WA 98660, Attn: Customer Service.

PRODUCT WARRANTY SCHEDULE

PRODUCT	WARRANTY PERIOD
727184 - 1746 GPH	2 year limited warranty
727186 - 3168 GPH	2 year limited warranty

PLANNING GRID

