



WD-1 Cut Sheet



Features

- LCD Display, Easy Operation
- Addressing Button

Overview

The WD-1 water detector can be used in one of two ways. First, it can be used to simply monitor the floor or a space for water... as a leak-detector. The other way the WC-1 can be used is as a water-verification monitor. When used in this way, the water detector is placed where runoff will accumulate (or where water is being introduced to the growing medium). Each output (solenoid or pump) on the Aqua-x can be "assigned" to a specific WD-1. Every time the solenoid or pump assigned to the WD-1 is activated by the Aqua-X, the WD-1 must detect water within an adjustable delay time. If water is not detected (pump or solenoid failure) the Aqua-x will send out a user alert notifying of the "irrigation failure". Up to 25 WD-1 can be connected to a single Aqua-x.

M Product Specifications

Package Content

- 1 x Water Detector
- 1 x Touch Spot
- 1 x RJ12 T-Splitter
- 1 x 16ft RJ12 Cable

Working Environments

Temperature 32-122°F, Humidity=90%

Package Dimensions

160mm(L) x 86mm(W) x 86mm(H)

Dimensional Diagram

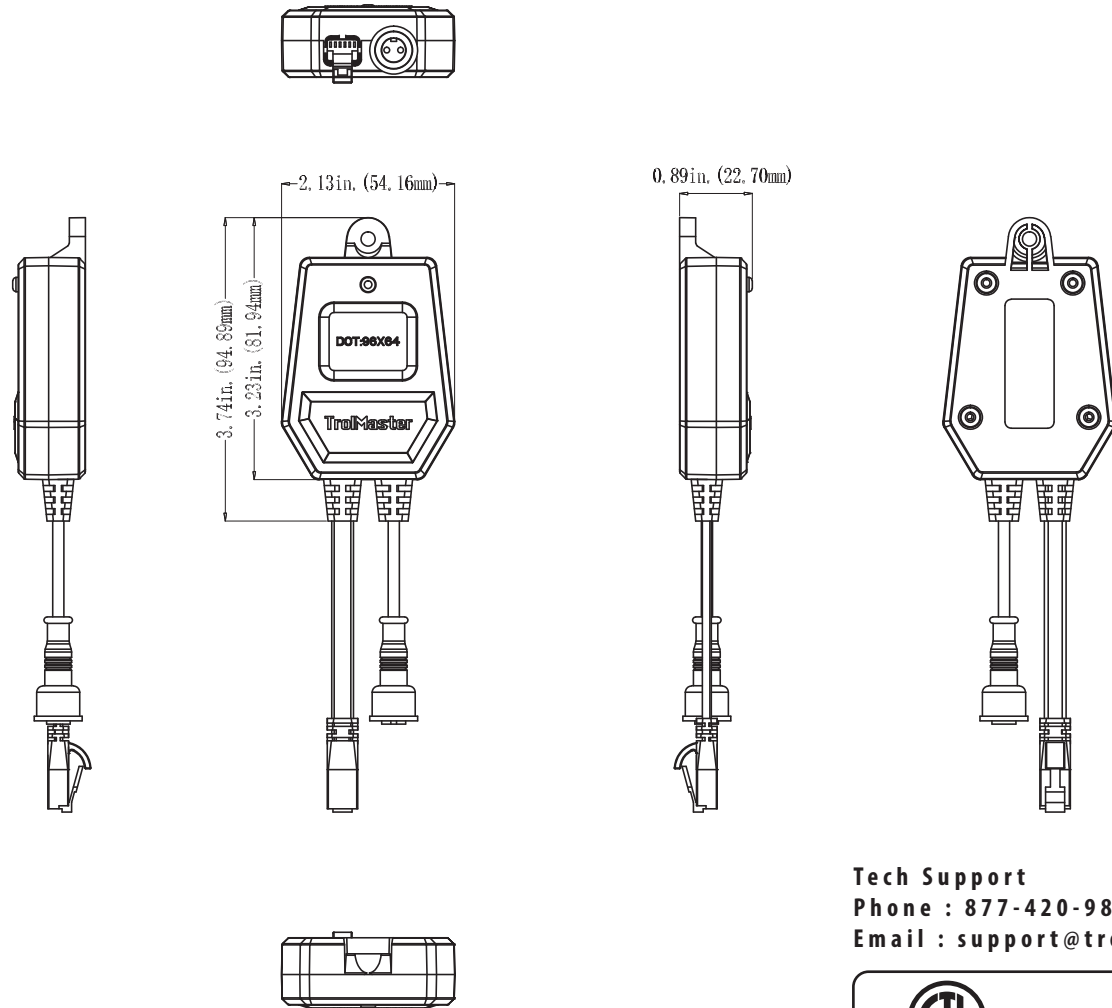

Tech Support

Phone : 877-420-9876

Email : support@trolmaster.com



Intertek
5008191

CONFORMS TO
UL STD.61010-1
CERTIFIED TO CSA STD.
C22.2#61010-1